



ECONOCAST I CAST IRON BOILERS

**INSTALLATION, OPERATION & MAINTENANCE
DOCUMENTATION**

STOKVIS ENERGY SYSTEMS
96R WALTON ROAD
EAST MOLESEY
SURREY
KT8 0DL
TEL: 020 8783 3050 / 08707 707 747
FAX: 020 8783 3051 / 08707 707 767
E-MAIL: info@stokvisboilers.com
WEBSITE: www.stokvisboilers.com

FEB1997

INDEX

Brief Specification	3
Location	3
Shipping Contents	3
NOx	3
General Design Considerations	3
Installation	3
Table 1 Boiler Outputs	4
Table 2 Dimensions	4
Fig1 Boiler Dimensions	5
Fig2 Boiler Door Clearance	5
Fig3 Boiler Base and Clearances	6
Table 3 Access and Clearance	6
Water Circulation Systems	7
Gas Supply	7
Oil Supply	7
Table 4 Heat Input and Firing Rate	8
Table 5 Hydraulic Information	8
Flue	9
Ventilation	9
Table 6 Flue and Ventilation	9
Table 7 Nuway Gas Burners	10
Table 8 Nuway Oil Burners	10
Table 9 Riello Gas Burners	11
Table 10 Riello Oil Burners	11
General Assembly Of Boiler	12
Foundation	12
Water Connections	12
Section Assembly	12
Boiler Platework and Mountings	
Fig 9 Assembled Boiler Block	14
Jacket Assembly	15
Fig 24 Jacket Assembly	18
Fitting Flue Pipe	19
Fitting Pressure Jet Burners	19
Electrical Connections	19
Electrical Safety Checks	19
Fig 25 Electrical Installation General	20
Fig 26 Wiring Diagram On/Off Boilers	21
Fig 27 Wiring Diagram High/Low Boilers	22
Fig 28 Wiring Diagram Pump Overrun And Volt Free Contacts	23
Commissioning Boilers	24
Maintenance Of Boiler	24
Component Replacement	25
Spare Parts	25
Users Guide	26
Health and Safety Information	27
Control Of Substances Hazardous To Health	27

Brief Boiler Specification

The Econocast 1 is a cast iron sectional boiler for pressure jet oil firing or forced draught gas firing and is supplied complete with combustion and control equipment. The

boiler is supplied in separate sections for assembly on site. All models can be supplied with the sections works assembled to special order.

The boiler is CE Marked on PIN 87AR17 to:-

Gas Directive
Boiler Efficiency Directive
Low Voltage Directive
Electromagnetic Compatibility Directive

and conforms to the requirements of :-

prEN 303 Parts 1 and 3 For Boilers
BSEN676 Gas Burners
BSEN267 Oil Burners

The boiler is suitable for central heating and indirect hot water supply at working pressures not exceeding 4.0 bar (60 lbf/sq.in). The boiler must not be used for direct hot water supply.

The boiler is provided with a comprehensive control panel containing control and limit thermostats, thermometers, altitude gauge, illuminated On/Off switch, "boiler on" lamp, and control box lock out lamp. Output signals are available for remote indication. An optional pump over-run timer is available for inclusion in the boiler control panel to time shunt pumps etc.

All models are available with Nu-Way or Riello oil or gas burners and the gas combinations are CE Marked and other combinations can be supplied.

Location

The boiler should be located on a level foundation of brick or concrete, capable of supporting the weight of the boiler when filled and 100 mm high. The front edge of the plinth should not extend forward of the front of the boiler case as this may interfere with the burner.

The boiler is cleaned from the front and top, and should be positioned so that adequate access is provided. It is recommended that at least 300 mm (12") clearance be allowed between the boiler and the walls of the boiler house. The clearance at the front should be equivalent to the length of the boiler.

Where more than one boiler is installed, the distance between them may be reduced to a minimum of 75 mm (3") provided that access to the top of the boilers from one side is possible. In the case of the shorter boilers (models 80, 106 and 133) access for top cleaning may be gained from the front of the boiler, side access is not essential. It must be remembered that the boilers burner door hinges and that extra clearance may be required to do this particularly when gas burners with

large gas trains are fitted. The above dimensions do not take into account the clearances required for pipe work, flues and other associated equipment.

Shipping Contents

This boiler is supplied shrink wrapped onto a single pallet and small burners are supplied in a single carton and larger gas burners have the gas train supplied on a small separate pallet. The boiler tie rods, jacket frame and cleaning tools are supplied in a separate tube for the models 160 to 292 inclusive.

NOx

Typical NOx figures depending on the boiler size and burner combinations are as follows :

Gas : 43 ppm at 9% CO2 wet - equivalent to 65 ppm Dry Air Free (DAF) or 114 mg/kWh on net boiler input.

Oil : 80 ppm at 12% CO2 wet - equivalent to 115 ppm Dry Air Free or 206 mg/kWh net boiler input. .

General Design Considerations

The installation of the boiler must be in accordance with the following regulations :

National Building Regulations
Local Building Regulations
The Building Standards (Scotland) (Consolidation) Regulations
I.E.E. Regulations (BS7671)
Local Water Byelaws
Local Gas Service Area Recommendations
Local Authority Recommendations
BS 5440 Pt1 1978 Flues
BS 5440 Pt2 1976 Air Supply

BS 6644 1991 Specification for the installation of gas fired hot water boilers of rated input between 60 kW and 2 MW
CP 342 Pt2 1974 Code of practice for centralised hot water supply buildings other than individual dwellings

British Gas Publications :
IM/2 Purging procedures

IM/5 Soundness testing

IM/16 Installation of gas pipe work and boosters

IM/11 Flues for commercial boilers

Health and Safety Executive Guidance Note PM5 :-
Automatically controlled steam and hot water boilers
C.I.B.S.E I.H.V.E Guide Parts A, B and C.

Installation

It is the Law that this appliance is installed and serviced only by a competent person e.g. a C.O.R.G.I registered installer or British Gas.

Page 3 THIS APPLIANCE MUST BE EARTHED

Boiler Outputs

Table 1

MODEL	A mm	NUMBER OF SECTIONS	OUT PUT		WEIGHT EMPTY* Kg	WATER CONTENT L
			kW	x1000 Btu/h		
45	500	3	45	154	326	42
60			60	205		
80	625	4	80	273	416	57
106	750	5	106	362	506	70
133	875	6	133	454	596	85
160	1000	7	160	546	685	100
187	1125	8	187	639	775	113
213	1250	9	213	727	865	129
240	1375	10	240	820	955	142
266	1500	11	266	908	1044	157
292	1625	12	292	997	1134	171
312	1750	13	312	1065	1143	186
329	1875	14	329	1123	1233	202
350	2000	15	350	1194	1323	217

* Includes approximate allowance for burner

Dimensions

Table 2

*

MODEL	BURNER PROJECTION B				FLUE SPIGOT SIZE mm	COMBUSTION CHAMBER RESISTANCE m.bar	COMBUSTION CHAMBER	
	NU WAY		RIE LLO				DIAMETER mm	LENGTH mm
	OIL	GAS	OIL	GAS				
45	NOT	NOT	390	390	150	0.1	460	220
60	AVAILABLE	AVAILABLE				0.2		
80	145	230	390	390	150	0.25	460	344
106	145	230	390	390	150	0.5	460	466
133	265	460	390	390	150	0.6	460	588
160	265	460	468	580	200	0.6	460	710
187	265	520	468	580	200	0.55	460	832
213	330	520	468	580	200	0.8	460	954
240	330	520	468	580	250	0.95	460	1076
266	330	520	468	580	250	1.2	460	1198
292	520	673	468	580	250	1.3	460	1320
312	520	673	468	580	300	1.5	460	1442
329	520	673	468	580	300	1.8	460	1564
350	520	673	468	580	300	2.2	460	1686

* This is the nominal o.d. flue spigot size only and larger flue sizes may be needed depending on site conditions.

Figure 1 Dimensions

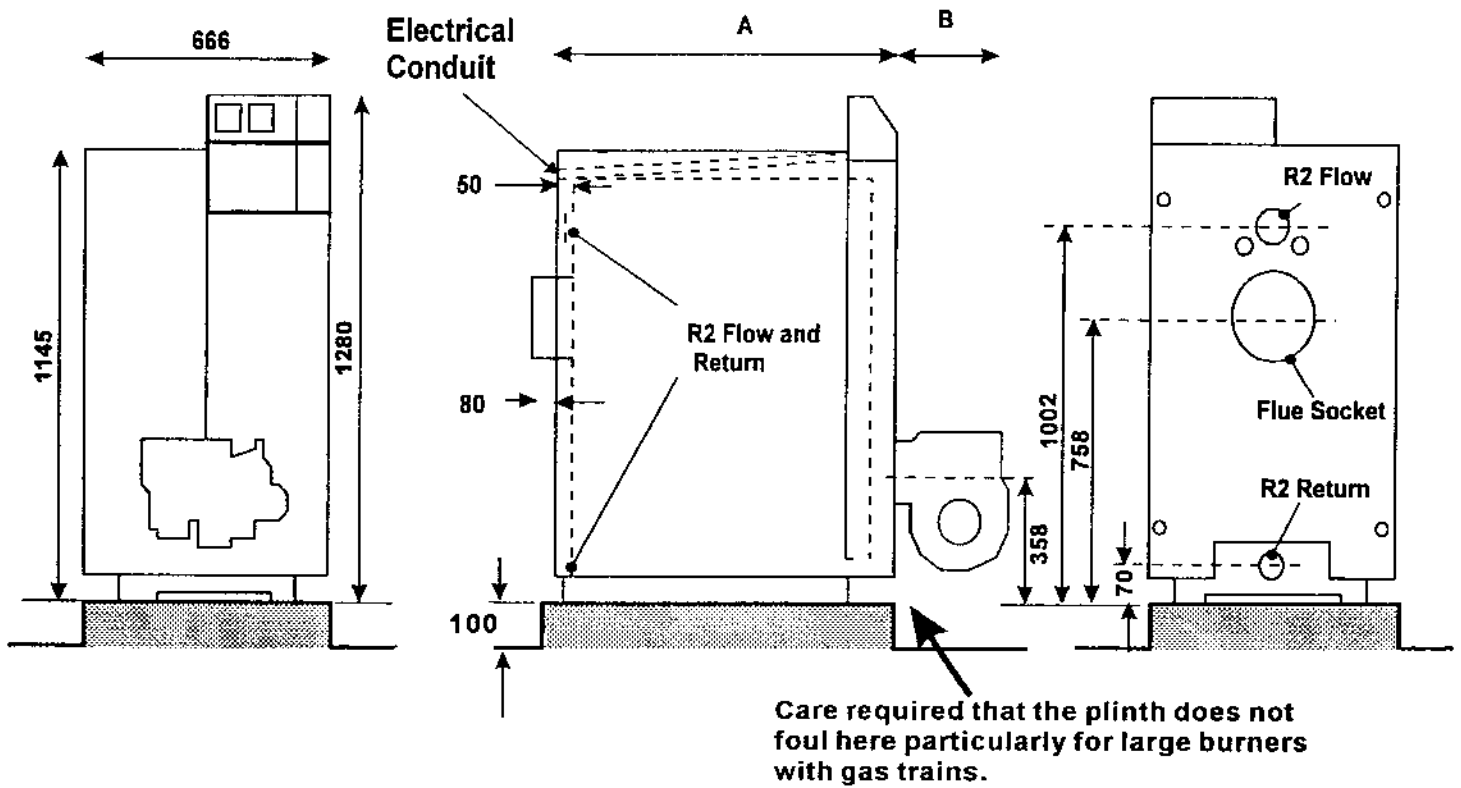
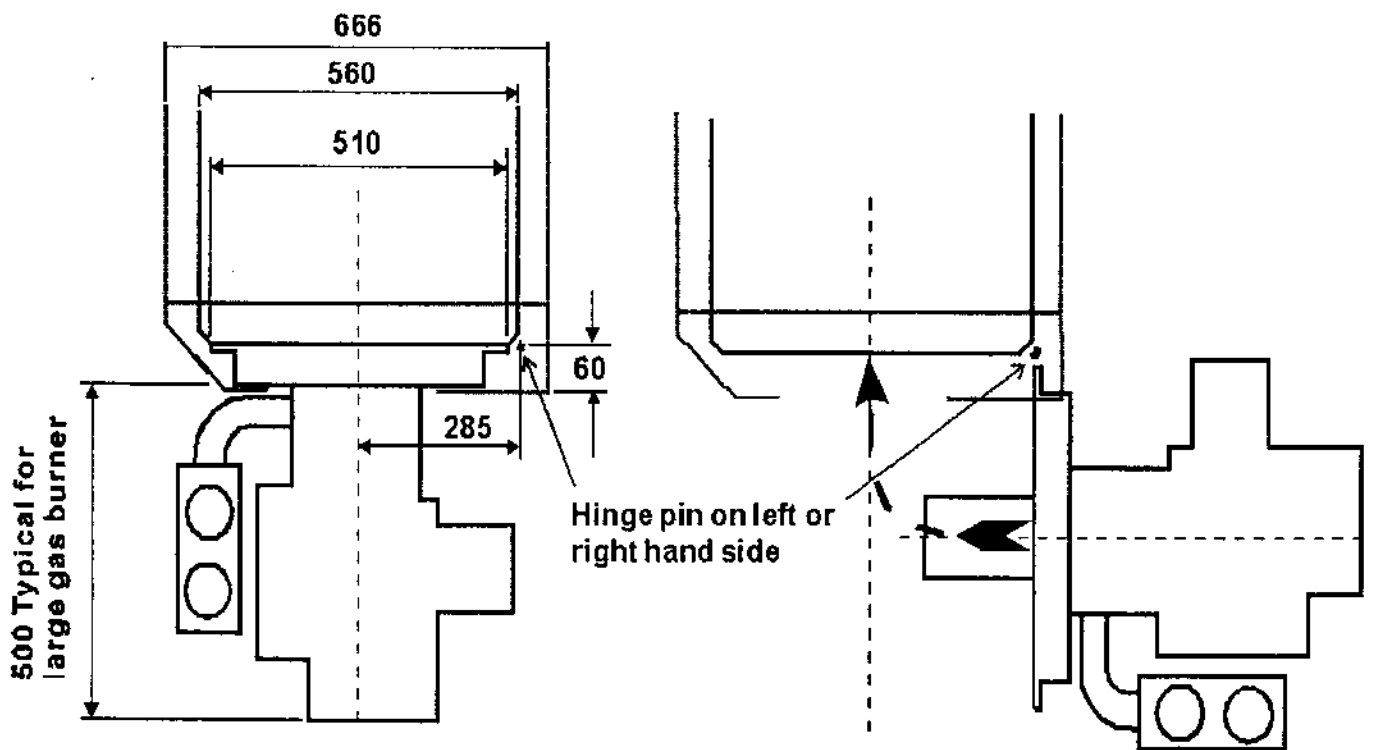

Figure 2 Boiler Door Clearances



IMPORTANT: Care must be taken to leave sufficient space between adjacent boilers or the boiler and any obstruction if the boiler is to be maintained by opening the boiler door without removing the burner (and gas train).

Figure 3 Base And Clearances

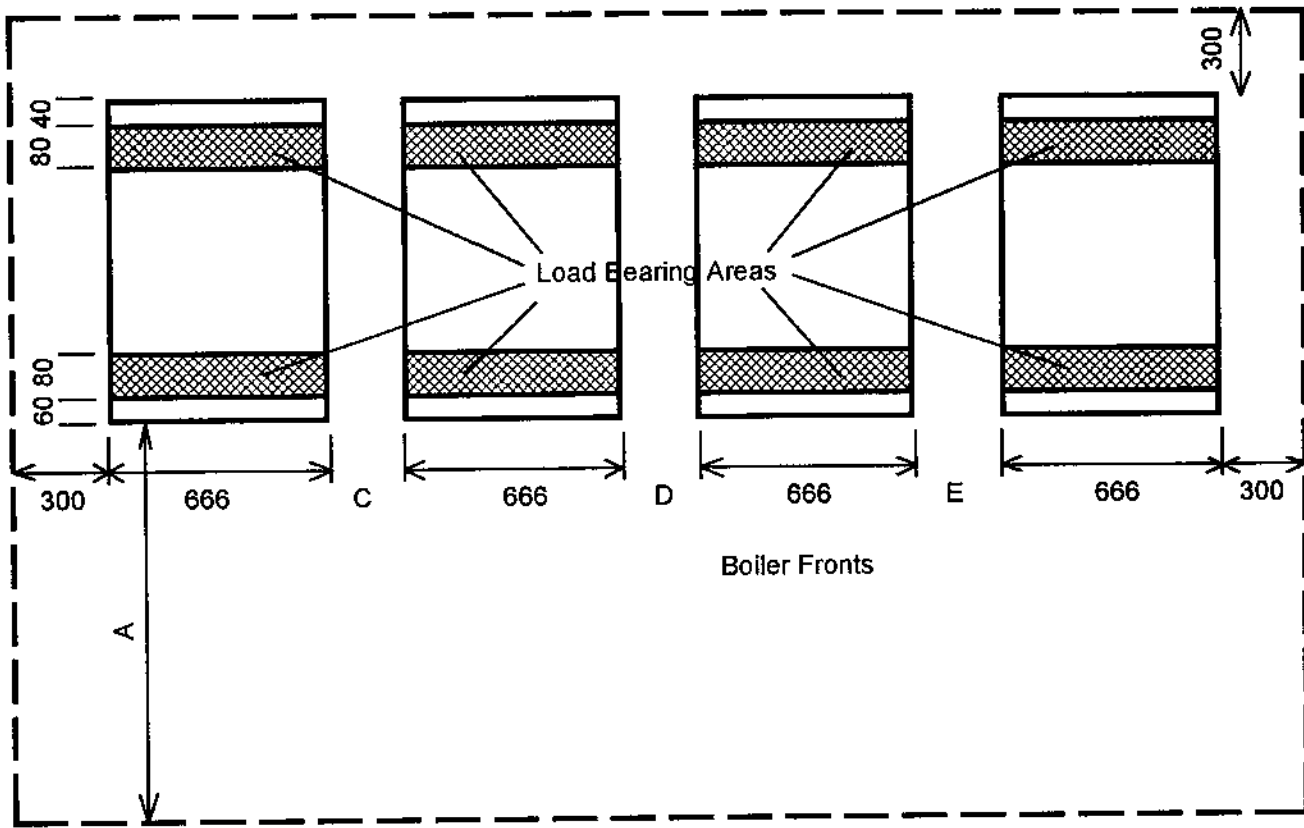

Table 3 Access And Clearances

NO. OF BOILERS	MODELS	DIMENSIONS		
		C	D	E
2	ALL	75	-	-
3	45/60,80,106 AND 133	75	75	-
3	160 TO 350 INCLUSIVE	*75	*300	-
4	45/60,80,106 AND 133	75	75	75
4	160 TO 350 INCLUSIVE	75	300	75

* In this case dimensions C and D may be reversed. NB Larger models with gas burners may require larger clearances to accommodate gas trains. Please consult Stokvis.

NB: For 2 or more boilers with the above clearances, for maintenance and cleaning remove burner before opening the boiler door.

Water Circulation System

The installation must be in accordance with the regulations given under General Design Considerations and the water circulation system should be installed in accordance with the requirements of BS 6880..

The flow and return connections are on the rear face of the back section.

A time delay of approximately 10 minutes should be incorporated between the burner switching off and the cessation of water flow in order to dissipate residual heat and prevent high temperature "lock out". A pump over run relay is available as an optional extra. If threeway mixing or diverting valves are installed in the system, they should not be of such a type that flow through the boiler is totally interrupted. If fully closing valves are used, a bypass should be fitted. It is recommended that the minimum flow rate through the boiler is equivalent to a temperature difference between flow and return of 35°K (63°F) at rated output (see Table 5).

For satisfactory operation, the pressure including any effect of the circulating pump imposed on the boiler should not be less than 2.0 m (6'5") head of water. It is essential when applying the boiler to a system to avoid, by design, a return water temperature of below 45°C (112°F) as this can lead to condensation.

The boiler is supplied with altitude gauge of range 0 - 4 bar. A 0 - 1 bar gauge is available and should be specified for low head applications.

Boiler water systems should be thoroughly flushed and cleaned before a new boiler is installed and system water should be treated by a reputable specialist and best practice observed. Consideration should be given to the fitting of sludge traps and strainers if site conditions warrant them.

The boiler does not contain aluminium. Suitable water treatment products are:

Sentinel X100 manufactured by Grace Dearborn Ltd and Copal manufactured by Femox Ltd.

The boiler is supplied with thermostats suitable for a maximum flow temperature of 90°C (194°F). The maximum operating temperature is 120°C (248°F) and thermostats for this application are available and should be specified, if required. In all cases it must be remembered that the boiler flow temperature must be at least 17°C (30°F) below the saturated steam temperature equivalent to the pressure at the highest point of the system.

If the open vent and/or safety valves are to be connected to the Rc1/2 tappings provided on the back section, the flow pipe will require a minimum horizontal run of 80 mm to clear the elbow fittings. To accommodate this horizontal run of flow pipe the flue connection will need a minimum of 180 mm of horizontal run.

Gas Supply

The local gas supply authority should always be contacted at the design stage to ensure an adequate supply is available.

An existing service pipe must not be used without prior consultation with the local gas supply authority and the supply must be made through a suitable meter. The boilers require a minimum inlet gas pressure at the boiler gas inlet of 17.5 mbar (7.0 in.wg). A gas isolating valve and union should be provided .

NB. The firing rates are based on thermal efficiency of :-

Oil : 83% on the gross calorific value of the fuel (87.4% net).

Gas : 81% on the gross calorific value of the fuel (90% net).

Oil Supply

The boiler is suitable for firing with either 28 Second Kerosene or 35 Second Gas Oil and this should be specified when ordering .

A single pipe oil supply with the oil available at a slight positive pressure is generally required though the burners own oil pumps can provide some lift of the oil depending on the volume flow and the lift required.

For dual fuel burners a two pipe oil supply system is generally recommended unless the burner is fitted with an oil pump clutch. An oil filter and isolating valve should be provided and the burner connected to the oil supply with a flexible oil hose. The hose and filter are generally supplied with the burner.

Table 4 Heat Input and Firing Rate

MODEL	HEAT OUTPUT		HEAT		INPUT		FIRING RATE			
	kW	1000 Btu/h	OIL		GAS		OIL		GAS	
			kW	1000 Btu/h	kW	1000 Btu/h	L/h	Gal/h	cu.M/h	cu.ft/h
45	45	154	54	185	56	190	5.0	1.1	5.3	187
60	60	205	72	247	74	253	6.7	1.5	7.0	247
80	80	273	96	329	99	337	8.9	2.0	9.4	332
106	106	362	128	436	131	447	11.9	2.6	12.4	438
133	133	454	160	547	164	560	14.9	3.3	15.5	547
160	160	546	193	658	198	674	18.0	4.0	18.8	664
187	187	638	225	769	231	788	21.0	4.6	21.7	766
213	213	727	257	876	263	897	24.0	5.3	24.9	879
240	240	819	289	987	296	1011	27.0	5.9	28.0	988
266	266	908	320	1093	328	1120	30	6.6	31	1094
292	292	996	352	1200	360	1230	33	7.3	34.0	1200
312	312	1065	376	1283	385	1314	35	7.7	36.2	1278
329	329	1123	396	1352	406	1386	36.9	8.1	38.2	1348
350	350	1194	422	1439	432	1474	39.4	8.6	40.6	1434

Table 5 Hydraulic Information

MODEL	MINIMUM RECOMMENDED FLOW									
	EQUIVALENT TO 35K (63F) DT FLOW/RETURN AT RATING				EQUIVALENT TO 11K (20F) DT FLOW/RETURN AT RATE				WATER CONTENT	
	L/s	Head m.wg	GPM	Head Ft.wg	L/s	Head m.wg	GPM	Head Ft.wg	L	Gal's
45	0.31	0.01	4.04	0.01	0.97	0.02	12.84	0.07	42	9.2
60	0.41	0.01	5.38	0.01	1.30	0.04	17.13	0.13	42	9.2
80	0.54	0.01	7.18	0.01	1.73	0.06	22.83	0.18	57	12.5
106	0.72	0.01	9.51	0.01	2.29	0.10	30.26	0.33	70	15.4
133	0.90	0.02	11.93	0.06	2.88	0.17	37.96	0.55	85	18.7
160	1.09	0.03	14.35	0.1	3.46	0.25	45.67	0.82	100	22.0
187	1.27	0.04	16.78	0.13	4.05	0.35	53.38	1.15	113	24.8
213	1.45	0.05	19.11	0.16	4.61	0.47	60.80	1.50	129	28.4
240	1.63	0.06	21.53	0.19	5.19	0.60	68.50	2.00	142	31.2
266	1.81	0.08	23.86	0.26	5.76	0.75	75.92	2.50	157	34.5
292	1.99	0.11	26.19	0.36	6.32	0.95	83.35	3.00	171	37.6
312	2.12	0.14	27.99	0.46	6.75	1.50	89.05	4.95	184	40.4
329	2.24	0.18	29.51	0.59	7.12	1.70	93.9	5.61	197	43.3
350	2.38	0.23	31.40	0.76	7.58	2.00	99.9	6.60	211	46.4

Flue

The installation must be in accordance with the regulations given under General Design Considerations.

The nominal flue size should not be less than that of the boiler flue connection socket and the flue must be self supporting as the flue socket is non load bearing.

The flue gas volumes given in Table 6 are quoted at S.T.P. (Standard Temperature and Pressure of 15°C and 1013.5 m.bar) but may vary slightly with site conditions.

The flue should be designed to give a balanced draught (zero) at the boiler flue socket as the burners are designed to overcome all of the combustion chamber resistance.

NB. The flue spigot is nominally 150mm for 45, 60, 80, 106 and 133 kW models, 200 mm for the 160, 187 and 213 kW models, 250 mm for the 240 to 292 models and 300 mm for all larger sizes. Depending on boiler size and site conditions a larger flue size may be needed and the flue system should be designed for each particular site.

Ventilation

The installation must be in accordance with the regulations given under General Design Considerations.

Table 6 Flue and Ventilation

MODEL	FLUE GAS VOLUME AT S.T.P				NOMINAL FLUE SPIGOT SIZE * mm	VENTILATION					
	OIL		GAS			NATURAL		MECHANICAL			
	L/s	cu.ft/m	L/s	cu.ft/m		LOW LEVEL	HIGH LEVEL	INLET	AIR	EXTRACT AIR	
					sq.cm	sq.cm	L/s	cu.ft/m	L/s	cu.ft/m	
45	18	39	19	40	150	518	259	50	105	33	70
60	24	52	25	54	150	601	301	66	140	44	94
80	32	69	34	72	150	712	356	88	187	59	125
106	43	91	45	95	150	855	428	117	248	78	165
133	54	115	56	120	150	1004	502	147	311	98	207
160	65	138	68	144	200	1153	577	177	374	118	249
187	76	161	79	168	200	1303	651	207	437	138	292
213	86	184	90	192	200	1446	723	235	498	157	332
240	97	207	102	216	250	1595	798	265	561	177	374
266	108	229	113	239	250	1739	869	294	622	196	415
292	118	252	124	263	250	1882	941	322	683	215	455
312	126	269	133	281	300	1993	996	345	730	230	486
329	133.16	284	140	296	300	2087	1043	363	769	242	513
350	141.66	302	149	315	300	2203	1101	387	819	258	546

S.T.P. is standard conditions of 1 bar and 15 ° C and typical gross flue gas temperatures are 180 to 220°C .

*This is the nominal socket size only. Larger boilers may require larger flues, e.g. Model 292 may require a 300 mm flue system depending on site conditions.

For natural ventilation - grilles with the minimum free areas as given in Table 5 (which are based on BS8644) for a single boiler should be provided at low and high level.

For exposed boiler houses - grilles should be provided on two or more external walls.

Care should be taken in siting boilers so that they are not affected by adverse draughts or situated next to powerful fans or other such equipment.

For underground boiler houses or those where communication with the outside is not possible then mechanical ventilation may be used. Volumes of air for mechanical ventilation are given in Table 6 for single boiler and are based on BS 6644.

For mechanically ventilated boiler houses it is possible to have mechanical inlet air at low level and natural extract air at high level and all volumes and grilles should be designed on the values given in Table 6. It is not permissible to have natural inlet air and mechanical extract. In all cases of mechanical ventilation the fans should be interlocked so that the boiler cannot run unless the fans are proved to be running.umes and grilles should be designed on the values given in Table 6.

The figures quoted in the Tables are based on BS 6644 for single boilers and are generally suitable for oil as well as gas fired boilers.

Table 7 Nuway Gas Burners

BOILER MODEL	BURNER MODEL	HEAD PRESSURE m.bar	HEAD SETTING	FAN STATIC PRESSURE m.bar	AIR INLET SETTING	START CURRENT Amps	RUN CURRENT Amps	FUSE RATING Amps	NOISE LEVEL dBA	NOISE LEVEL NR	GAS TRIN SIZE INCH
46	NOT AVAILABLE										
60	NGN3S1S150	7.7	-	-	1.1	1	0.6	5	72	65	3/4"
80	NGN5 S1S150	6.1	FIXED	1.8	35%	1	0.6	5	72	65	3/4"
106	NGN5 S1S150	8.6	FIXED	2.3	50%	1	0.6	5	75	68	3/4"
133	NGN7 S1S150	11.1	FIXED	3.9	45%	7	1.7	10	75	68	1"
160	NGN8 S1S150	7.3	FIXED	2.4	35%	7	1.7	10	75	68	1"
187	NGN8 S1S100	10.6	FIXED	2.9	45%	7	1.7	10	75	68	1"
213	NGN9 S1S100	11.7	FIXED	4.1	70%	7	1.7	10	75	68	1"
240	NGN13 S1S100	12.8	FIXED	2.8	45%	7	1.7	10	75	68	1 1/4"
266	NGN13 S1S100	12.1	FIXED	3.8	60%	7	1.7	10	75	68	1 1/4"
292	NGN15 S1S150	9.5	FIXED	6.0	25%	30	4.8	20	78	70	1 1/4"
312	NGN15 S1S150	10.3	FIXED	7.9	45%	30	4.8	20	78	70	1 1/4"
329	NGN15 S1S150	11.1	FIXED	8.6	60%	30	4.8	20	78	70	1 1/4"
350	NGN25 S1S150	8.5	FIXED	7.4	45%	30	4.8	20	78	70	1 1/4"

Table 8 Nuway Oil Burners

BOILER MODEL	BURNER MODEL	OIL NOZZLE	OIL PRESSURE bar	HEAD SETTING	AIR INLET SETTING	START CURRENT Amps	RUN CURRENT Amps	FUSE RATING Amps	NOISE LEVEL dBA	NOISE LEVEL NR
46	NOL3 S1S150	1.0 / 60 / S	14.5	1	(1.5 - 2.0)	1.5	1	6	60	58
60	NOL3 S1S150	1.35 / 60 / S	13.5	2	5	1.5	1	6	60	58
80	NOL5 S1S150	2.0 / 60 / S	10.6	L	-	1.5	1	6	60	58
106	NOL6 S1S150	2.5 / 60 / S	12.0	M	7	1.5	1	6	60	58
133	NOL6 S1S150	3.0 / 60 / S	12.4	H	FULL	7	1.7	10	70	63
160	NOL9 S1S150	3.5 / 60 / S	13.9	M	7	7	1.7	10	70	63
187	NOL9 T1S150	3.5 / 60 / S	19.0	H	7	7	1.7	10	70	63
213	NOL13 T1S150	2 @ 2.5 / 60 / S	12.0	M	7	7	1.7	10	70	63
240	NOL13 T1S150	2 @ 2.75 / 60 / S	12.4	M	7	7	1.7	10	70	63
266	NOL20/23T1S150	2 @ 3.0 / 60 / S	13.0	H	FULL	22	4.5	20	72	65
292	NOL20/23T1S150	3.0 & 3.5 / 60 / S	13.4	H	FULL	22	4.5	20	72	65
312	NOL20/23T1S150	2 @ 3.5 / 60 / S	13.0	H	FULL	22	4.5	20	72	65
329	NOL20/23T1S150	4.0 & 3.5 / 60 / S	13.7	H	FULL	22	4.5	20	72	65
350	NOL20/23T1S150	4.0 & 3.5 / 60 / S	14.5	H	FULL	22	4.5	20	72	65

Table 9 Riello Gas Burners

BOILER MODEL	BURNER MODEL	HEAD PRESSURE m.bar	HEAD SETTING	FAN STATIC PRESSURE m.bar	AIR INLET SETTING	START CURRENT Amps	RUN CURRENT Amps	FUSE RATING Amps	NOISE LEVEL dBA	INLET GAS SIZE INCH
46	GS10	3	0	-	23	2.5	0.9	5	58	3/4"
60	GS10	5.4	0	-	5.3	2.5	0.9	5	58	3/4"
80	GS20	2.4	0	-	1.7	6	1.4	6	64	3/4"
106	GS20	4	1	-	2.2	6	1.4	6	64	3/4"
133	GS20	4.3	2.5	-	4	6	1.4	6	64	3/4"
160	GS20	5	3	-	5	6	1.4	6	64	3/4"
187	RS28.1	4	3	7	30 Degrees	10	2.1	10	68	1 1/4"
213	RS28.1	5	4	7.6	40 Degrees	10	2.1	10	68	1 1/4"
240	RS28.1	7.1	5	8.3	50 Degrees	10	2.1	10	68	1 1/4"
266	RS38.1	4.3	3	7.7	2.6	15	2.9	15	70	1 1/4"
292	RS38.1	5.7	4	8.2	2.9	15	2.9	15	70	1 1/4"
312	RS38.1	6.5	MAX	9.3	3.3	15	2.9	15	70	1 1/4"
329	RS38.1	6.9	MAX	9.7	3.5	15	2.9	15	70	1 1/4"
360	RS38.1	7.3	MAX	10.5	3.8	15	2.9	15	70	1 1/4"

Table 10 Riello Oil Burners

BOILER MODEL	BURNER MODEL	NOZZLE SIZE DANFOSS	OIL PRESSURE bar	HEAD SETTING	AIR INLET SETTING	START CURRENT Amps	RUN CURRENT Amps	FUSE RATING Amps	NOISE LEVEL dBA
46	G7	1.0 / 60 / S	14.5	3	25	2.6	0.85	5	62
60	NOT AVAILABLE								
80	G20	1.75 60 S	14	3	3	6	1.4	6	66
106	G20	2.25 60 S	13	3	4	6	1.4	6	66
133	G20	3.00 60 S	12.5	3	5	6	1.4	6	66
160	RL28	2x 1.75 60 S	12.5	1	20 Degree	7.5	2.1	6	68.4
187	RL28	2x 2.25 60 S	13	2	30 Degree	7.5	2.1	6	68.4
213	RL28	2x 2.5 60 S	13	3	40 Degree	7.5	2.1	6	68.4
240	RL28	2x 2.75 60 S	13	4	50 Degree	7.5	2.1	6	68.4
266	RL38	2x 3.0 60 S	13	1	35 Degree	8.5	2.9	6	71.7
292	RL38	2x 3.25 60 S	13	1	42 Degrees	8.5	2.9	6	71.7
312	RL38	2x 3.5 60 S	12	2	50 Degrees	8.5	2.9	6	71.7
329	RL38	2x 3.5 60 S	14	2	55 Degrees	8.5	2.9	6	71.7
360	RL38	483.5 60 S	12	3	60 Degrees	8.5	2.9	6	71.7

NB:

- * RL28.1 on/off burner (but low flame start).
- * RL38 high/low burner only.
- * RS28.1 and RL28.1 single phase only (3 phase not available).

General Assembly Of Boiler

Boilers are sent out in separate sections to be assembled on site (unless specially ordered as works assembled). Accompanying the sections are the following packages:-

1. Instrument panel.
2. Jacket box.
3. Insulation (prefitted into the top and side panels).
4. Nipples, flue covers etc.
5. Tie rods and casing frame.
6. Burner.

The boiler consists of one front, one back and several middle sections which are identical.

Foundation

The boiler should be erected on a level foundation of brick or concrete typically 100 mm high capable of supporting the full weight of the boiler (see Fig. 3). On an existing base it may be necessary to provide steel shims to provide a level footing.

Water Connections

The flow and return connections are screwed 2 in.BSPfemale (Rc2) . The flow connection should be made to the top back of the boiler and the return connection to the bottom back of the boiler.

If the safety valve and open vent connections are made to the 1 1/2in.BSP female (Rc 1 1/2) connections each side of the flow connection the flow pipe will need a 80 mm horizontal run to clear these elbows before its first bend. To clear the flow pipe the flue pipe should run for 180 mm horizontally before its first bend.

It is important that only one flow and return connection are made to the boilers as described above.

Section Assembly

(Bracketed numbers refer to Key Numbers in Fig 9)

1. Place the back section (9) in the required position and support it vertically. All nipples should be wiped clean and checked for damage before assembly. No responsibility can be accepted for leaks attributed to damaged nipples and therefore a bruise on the nipple or port cannot be ignored. The nipples should be coated evenly with the red jointing compound provided. It is recommended that this is applied with a brush and it is essential that care is taken to ensure that this coating is free of grit or other solid particles.

2. Insert nipples (14) in the nipple holes of the back section (9). Ensure that they are put in straight, and tap them lightly into position, taking care not to damage the nipples (Figure 4).

Fig 4.

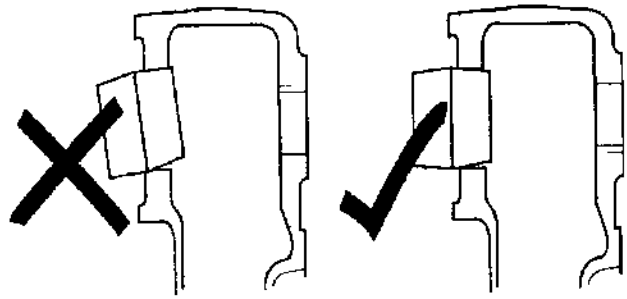

3. Apply 6 mm diameter sealing strip to the back section. The sealing strip is supplied on reels, and one length off the reel is sufficient for one section joint. Keep the sealing strip clean and free from dust and dirt, to ensure easy adhesion to the section. Apply the sealing strip to the groove around the perimeter of the section, above the top nipple hole, and around the centre flueway (Figure 5).

Fig 5.

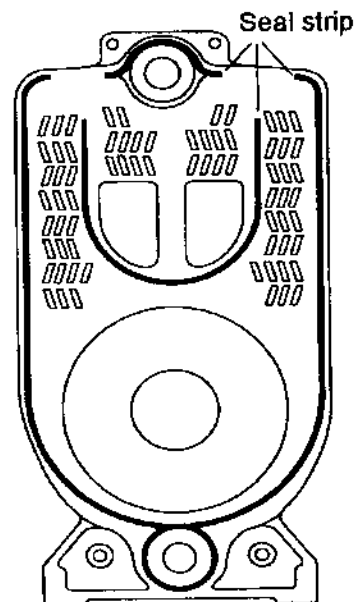

4. Prepare the pulling up tools, ready for use (see Figure 6). Oiling the pulling up rods will assist in pulling the sections together. Fit a nut on each M16 screwed rod, and screw along the rod approximately 375 mm (15"). Fit a washer on the rod followed by a pulling up plate.

Fig 6.

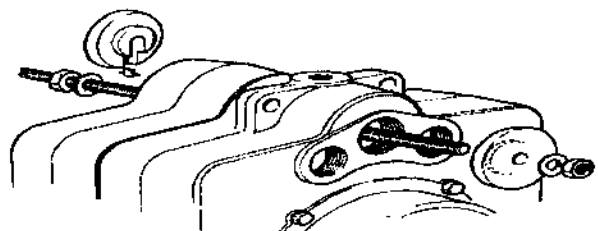

5. Offer a middle section (12) up to the back section (9), locating it correctly on the nipples (14) and lightly tap into place. Hold the middle section in position and insert the pulling up rods from the back. Fit a washer and nut on the end of each rod. Slip a flange over each rod in front of the middle section. Tighten the nut hand tight.

6. Ensure that the middle section is equally spaced from the back at each side. Tighten the nut on each rod evenly until the sections are pulled together as close as possible (Figure 7). The sealing strip will exude from the joint, and when correctly assembled only a thin line of sealant should be visible in the joint.

Fig 7.

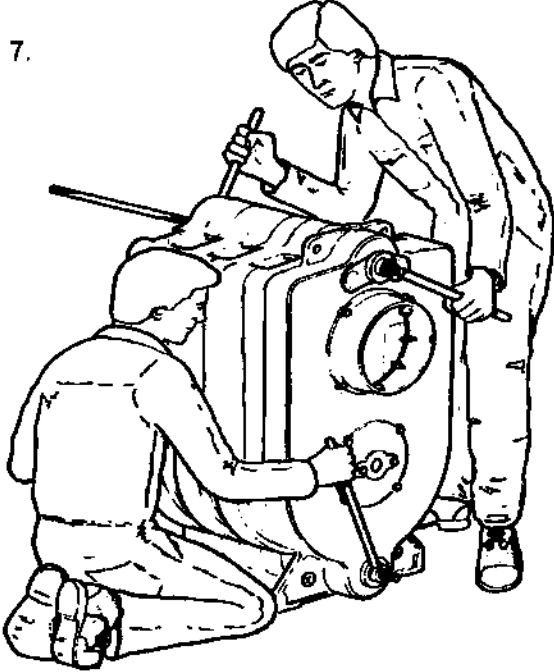

7. When the two sections are pulled up, slacken off the nuts, remove the flange and withdraw the pulling up rods. Screw the nut approximately 140 mm (5 1/2") further down the rod.

8. Clean the nipple holes in the middle section (12) just assembled and coat two nipples (14) with jointing compound as indicated above and insert them in the nipple holes. Repeat the procedure until all sections have been erected. As an aid to getting the next middle section to engage on the nipples of the last middle section the boiler front should be lifted by putting a 15 mm packing strip under the last middle section fitted. Always erect and pull up one section at a time until all sections have been erected.

9. When the front section (16) has been pulled up and before releasing the pulling up rods, insert the four tie rods (4,15) between the front and rear sections. Fit nuts (6) and washers to each end of each tie rod 4,15) and tighten. A torque wrench, although not essential will ensure even and correct tightening of the rods. A torque not exceeding 40 lb/ft should be applied.

UNDER NO CIRCUMSTANCES SHOULD THESE TIE RODS BE USED FOR PULLING SECTIONS TOGETHER

10. When the tie rods (4,15) have been fitted and tightened the pulling up rods should be removed. Check that the boiler is correctly positioned and level.

11. After assembly of the sections the drain cock may be fitted to the Rc 3/4 tapping in the back section. The, tappings should be plugged, the boiler filled and hydraulically tested to 1 1/2 times the normal working pressure ie 6 bar for 30 minutes.

In accordance with good practice, flush the boiler thoroughly after assembly and before connecting the system.

Boiler Platework and Mounting

1. Fit the flueway covers over openings. Before fitting each cover position a gasket (10) around the aperture, and ensure that the top of the cover beds down on the gasket (Figure 8). The covers with short baffles fitted should be fitted onto the rear flueways and then work forward until all this type of cover are used up.. Fit covers without baffles from this point to the front.

Fig 8.

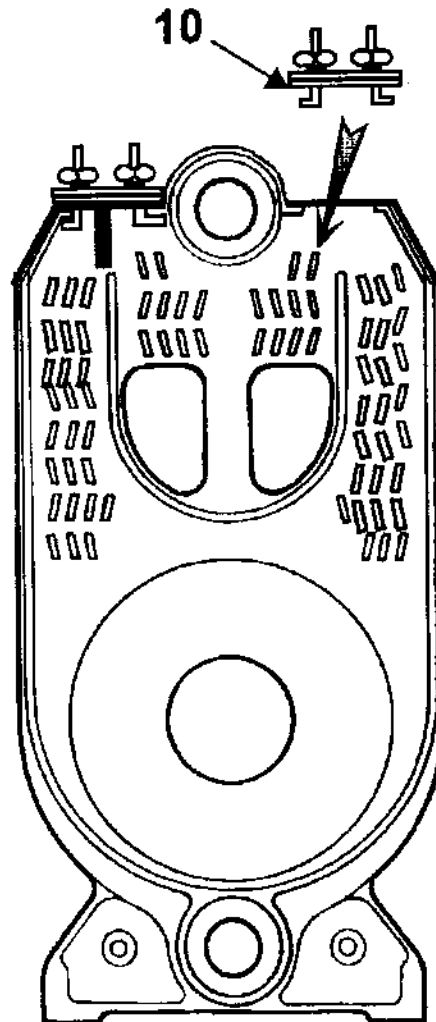

2. If required, fit the safety valve to one of the Rc 1 1/2 tappings on the back section, using an M and F elbow, and reducing bush if necessary. The open vent may be connected to the other Rc 1 1/2 tapping on the back section.

3. Plug the bottom Rc 1 1/4 tapping (27) in the front section. Bush the top tapping (17) to Rc 1/2 and fit the thermostat pocket which is packed with the control panel.

4. Remove the brass valve fitting (R 1/2) from the end of the altitude gauge capillary and make this into R 1/2 tapping (18) in the face of the front section (16) on the right hand side. This fitting is also packed with the control panel.

6. For the 13/312, 14/329 and 15/350 kW models only fit the water distributor (28) to the bottom return connection. This should be screwed in 12 mm to the welded stop mark on the threads and the joint made with hemp or similar. This welded stop mark should be pointing upwards to show that the holes in the distributor are pointing horizontal.

The distributor is supplied assembled but can be broken down on site into 3 shorter pieces and inserted into the boiler one piece at a time and reassembled with the locking screw if clearance behind the boiler is short.

Fig 9. Assembled Boiler Block

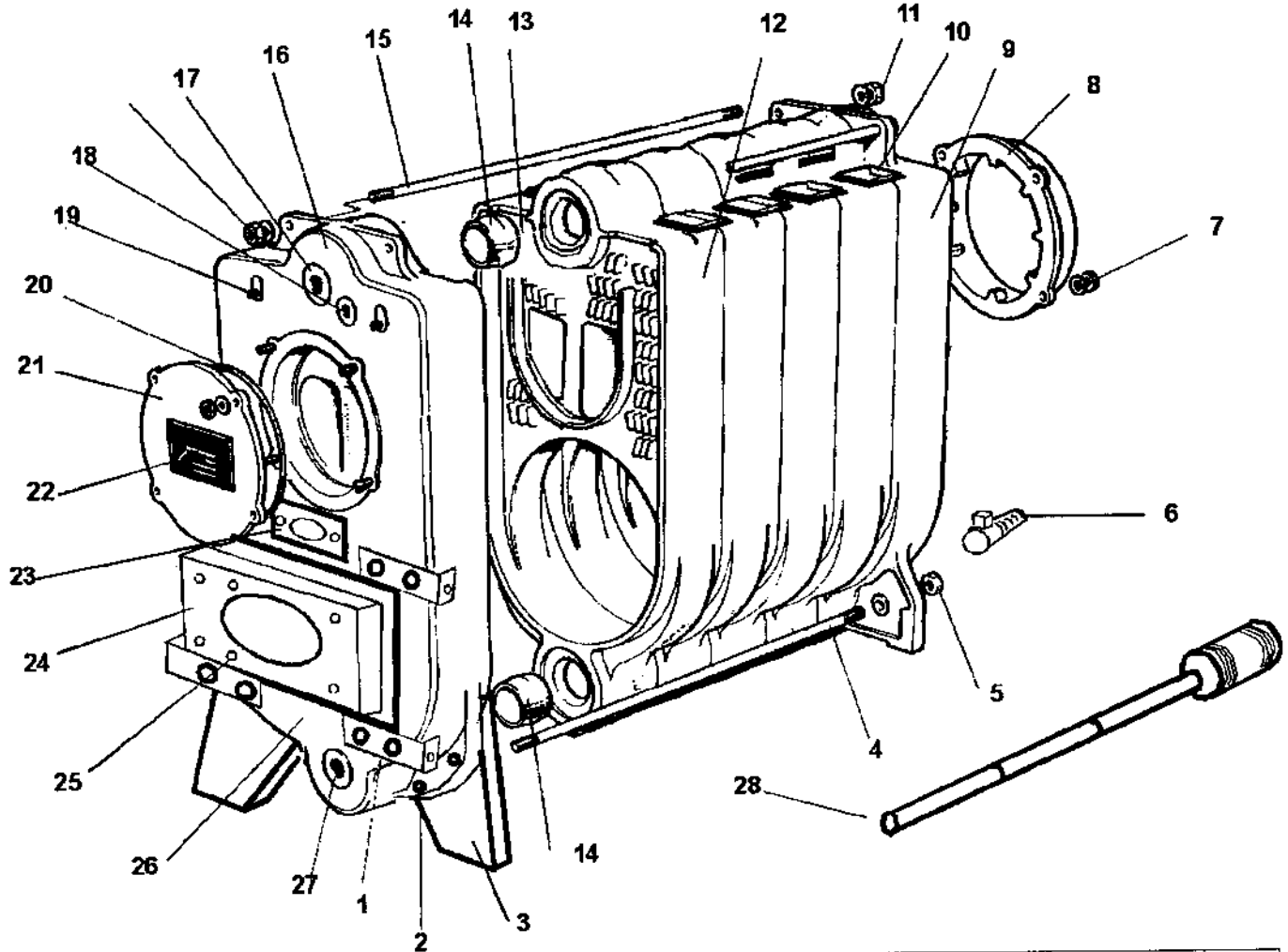

1	Jacket spacing bracket
2	Boiler foot M12 bolt
3	Boiler foot
4	Bottom tie rod
5	Tie rod nut and washer M16
6	Drain cock
7	Flue spigot M8 stud nut and washer
8	Flue spigot
9	Rear section
10	Flue cover, gasket and baffle set
11	Tie rod nut and washer M16
12	Middle section
13	Seal strip
14	Nipple
15	Top tie rod
16	Front section
17	Thermostat pocket tapping 1/2"
18	Altitude gauge tapping 1/2"
19	Fixing stud for jacket frame support bracket
20	Front clean out cover rope seal
21	Front clean out cover
22	Data plate
23	Sight glass assembly
24	Boiler door assembly
25	Test plug for boiler resistance
26	Boiler door rope seal
27	Bottom tapping 1 1/4"
28	Water distributor - Models 13 / 312, 14 / 329 and 15 / 350kW only

Jacket Assembly

Bracketed numbers refer to Key Numbers in Fig. 24

1. You will find 2 off M8 x 20 studs (64) fitted to the top of the front section and fit a frame mounting bracket (63) to these with M8 nuts. The return bend on this bracket should point towards the centre of the boiler.

Fig 10.

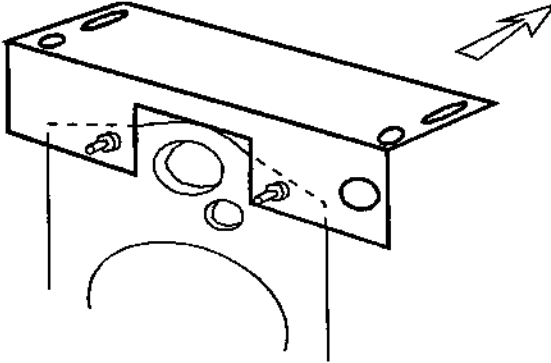

2. Similarly you will find 2 off M8 studs fitted to the back section and the other frame mounting bracket (50) should be fitted to these with the return bend pointing towards the centre of the boiler.

Fig 11.

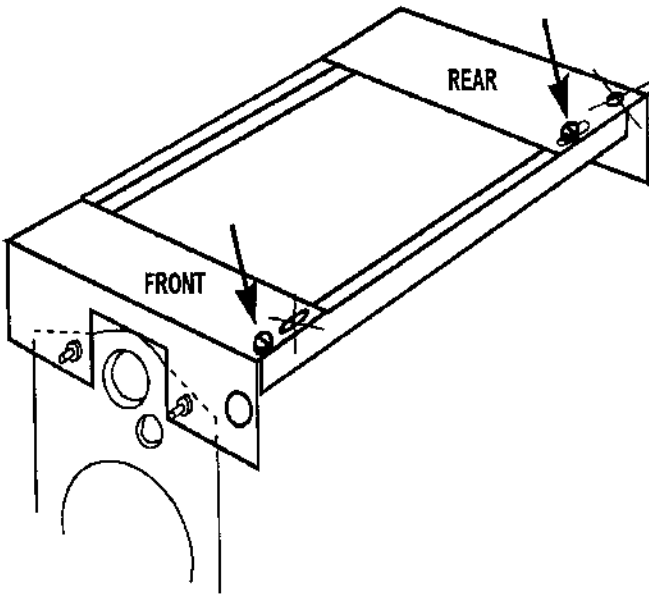

3. Take the square tube frame members (51) and fit to frame mounting bracket (50,63), one at each side of the boiler. At the front of the boiler align the holes in the frame mounting plate with the M6 tappings nearest to the end of the square tube frame members (51) and fit with M6x10 long screws (62). At the rear of the boiler align the slots in the frame mounting plate with the M6 tappings furthest from the end of the tubes and fit M6x10 long screws (52).

Page 15

4. Take the instrument panel (60) and open it by releasing the two countersunk screws and swinging the facia upwards on its hinges. Fit the instrument panel to the front frame mounting plate using 2 off M6x10 screws through the two holes in the base of the instrument panel into the 2 off M6 tappings in the frame mounting plate (63).

Route the 1 or 2 flexible electrical conduits from the control panel behind the two jacket locating brackets (item 44 Fig 24).

Fig 12.

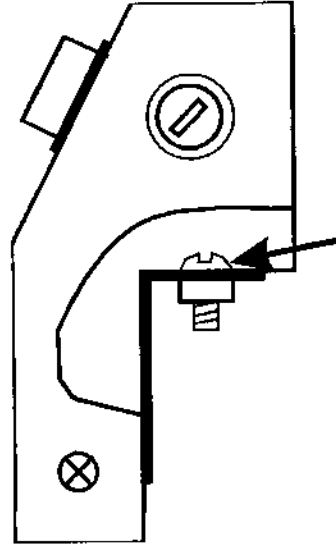

5. Route and fit the two thermostat and thermometer capillaries to the thermostat pocket fitted in the front section. Fit the altitude gauge to its self sealing fitting in the front section.

Fig 13.

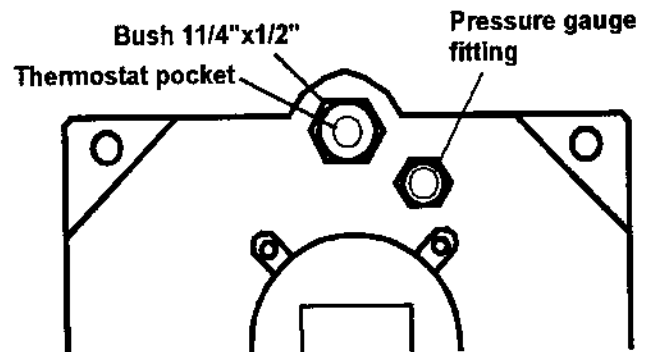

On high/low boilers fit the control, high/low, high limit thermostats and the thermometer bulbs into the extra deep (150 mm) thermostat pocket.

Fig 14.

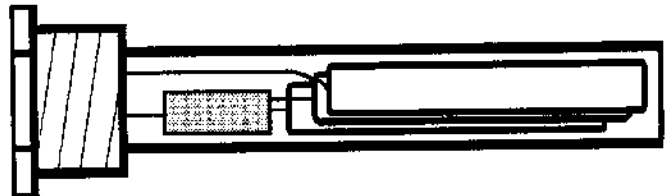

6. For small boilers (Models 45/60, 80 and 106) a single piece side panel width W is used.

Fig 15.

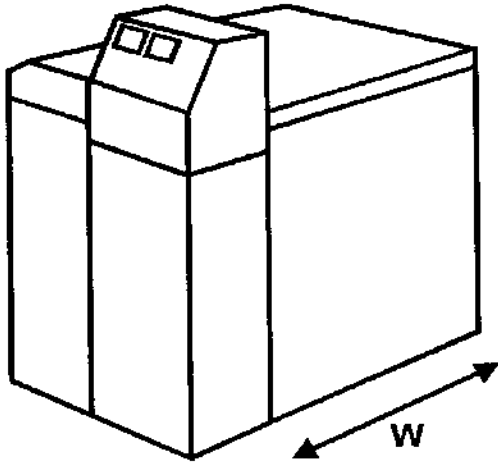

Table 11

MODEL	W mm
45/60	375
80	500
106	625

For larger boilers two side panels are used :

Fig 16.

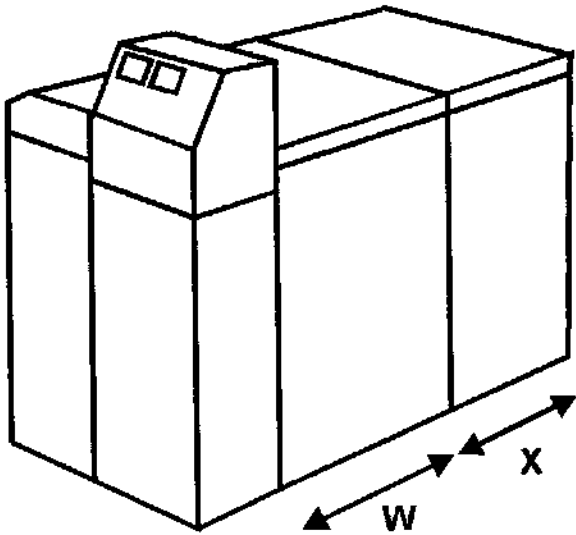

Table 12

MODEL	W mm	X mm
133	375	375
160	500	375
187	500	500
213	625	500
240	625	625

On the largest boilers three side panels are used.

Fig 17.

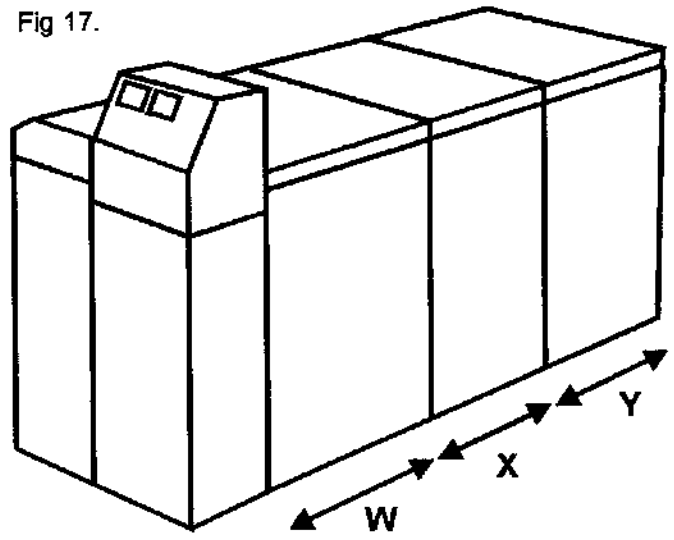
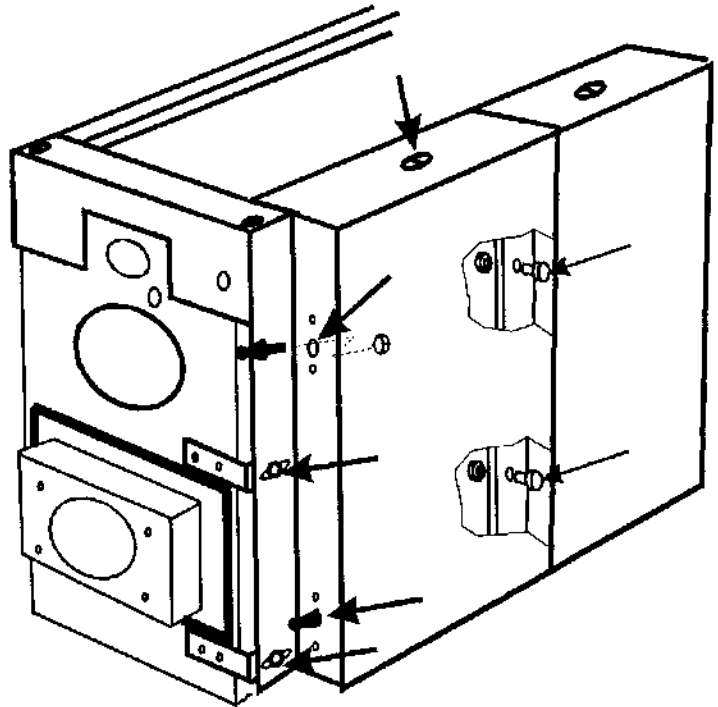

Table 13

MODEL	W mm	X mm	Y mm
266	500	500	375
292	500	500	500
312	500	500	625
329	500	625	625
350	625	625	625

7. For boilers with 2 or 3 side panels fix these together with M6x10 screws, nuts and washers (69). Fit 4 off ball studs (46) to the front of the side panels with M5x8 screws. Hang the side panels from the square tube frame members (51) and secure at the top using M6x35 long screws and nuts (70).

Fig 18.



8. fix the bottom of the front side panel to the locating brackets(44) prefitted to the front boiler section using M6x10 (67) screws into the captive nuts. Check that the 4 ball studs are already fitted as above.

The locating brackets (44) are delivered facing the wrong way for transport and must first be changed.

9. Fit 2 off M5 ball studs (71) to the top of each side panel using an M5x8 screw.

Fig 19.

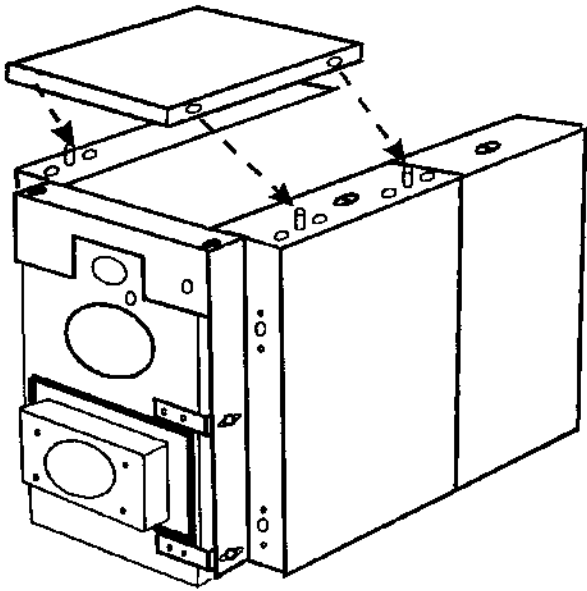

10. Fit the jacket top panels (55) to the top of the side panels by locating and pushing down so that the spring latches locate on the ball pins previously fitted.

11. Position the back insulation piece (48) into position by resting it up against the rear of the boiler.

Fig 20.

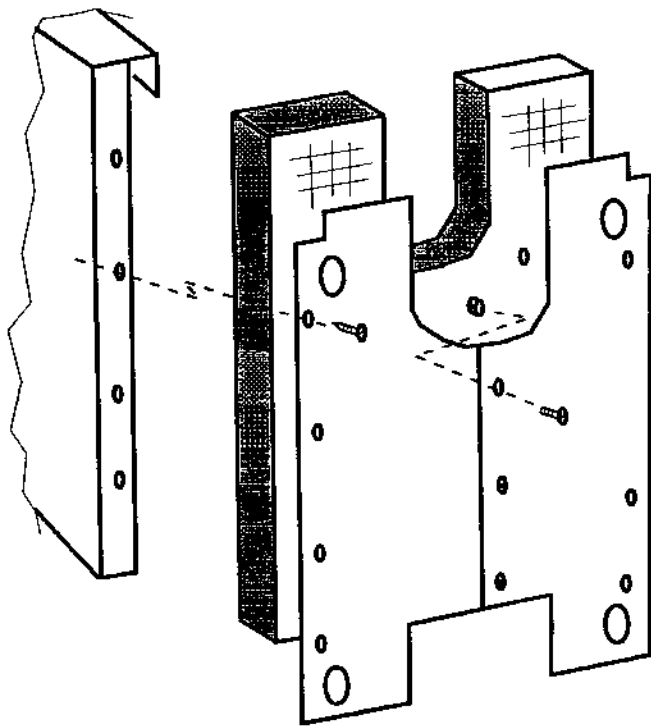

12. Fasten the two back panel halves (49,53) to each other using M6x10 screws and nuts. Then fasten the back panels to the side panels using 4 off No.10 self tapping screws (68).

The top of the back panels should fit under the rear top panel.

13. The jacket front panel is delivered as a single piece. The 4 off ball pins (46) should have been already fitted to the front edge of the jacket side panels with M5x8 screw.

Fig 21.

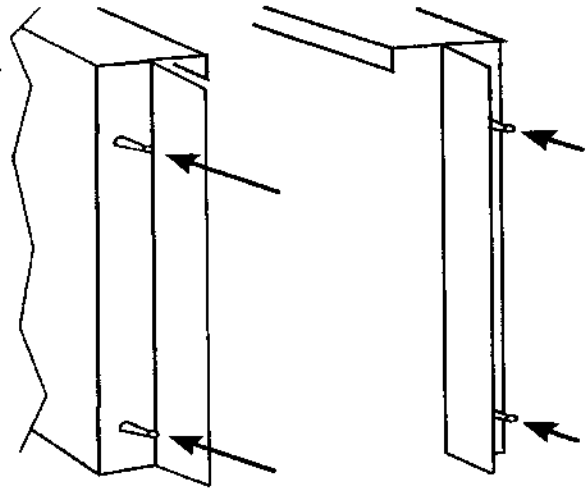

14. The jacket front panel then fixes to the front of the boiler by engaging the ball studs (46) in this order.

First: Locate the right hand ball pins onto the right hand latches making sure that the one (or two cables) (65) from the boiler control panel to the burner are routed through the slot in the right hand side of the front panel.

Fig 22.

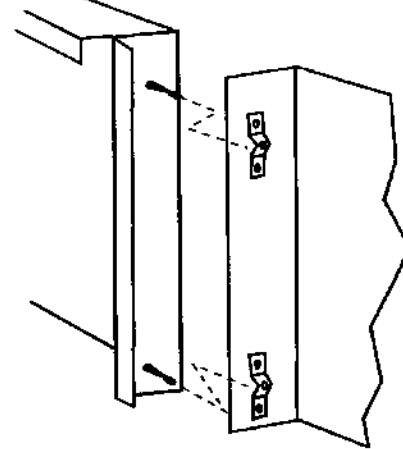

Second: Hook the top of the front panel into its slot in the jacket frame support bracket (63) by lifting it up and up and over and letting the tongue engage in the slot.

Fig 23.

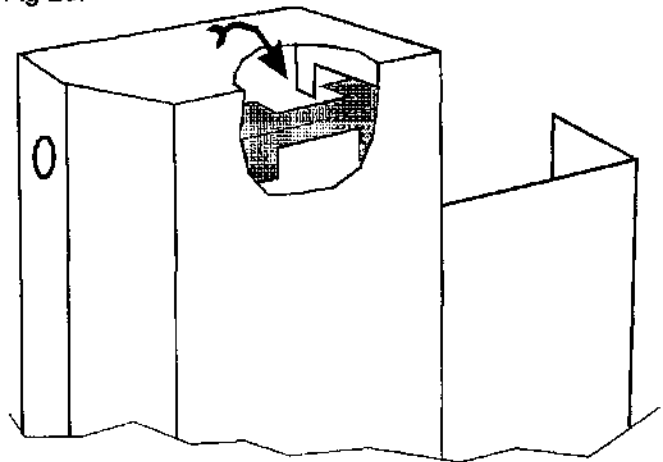

Third : Engage the left hand side ball studs onto their latches on the left hand side front panel.

Fig 24. Jacket Assembly

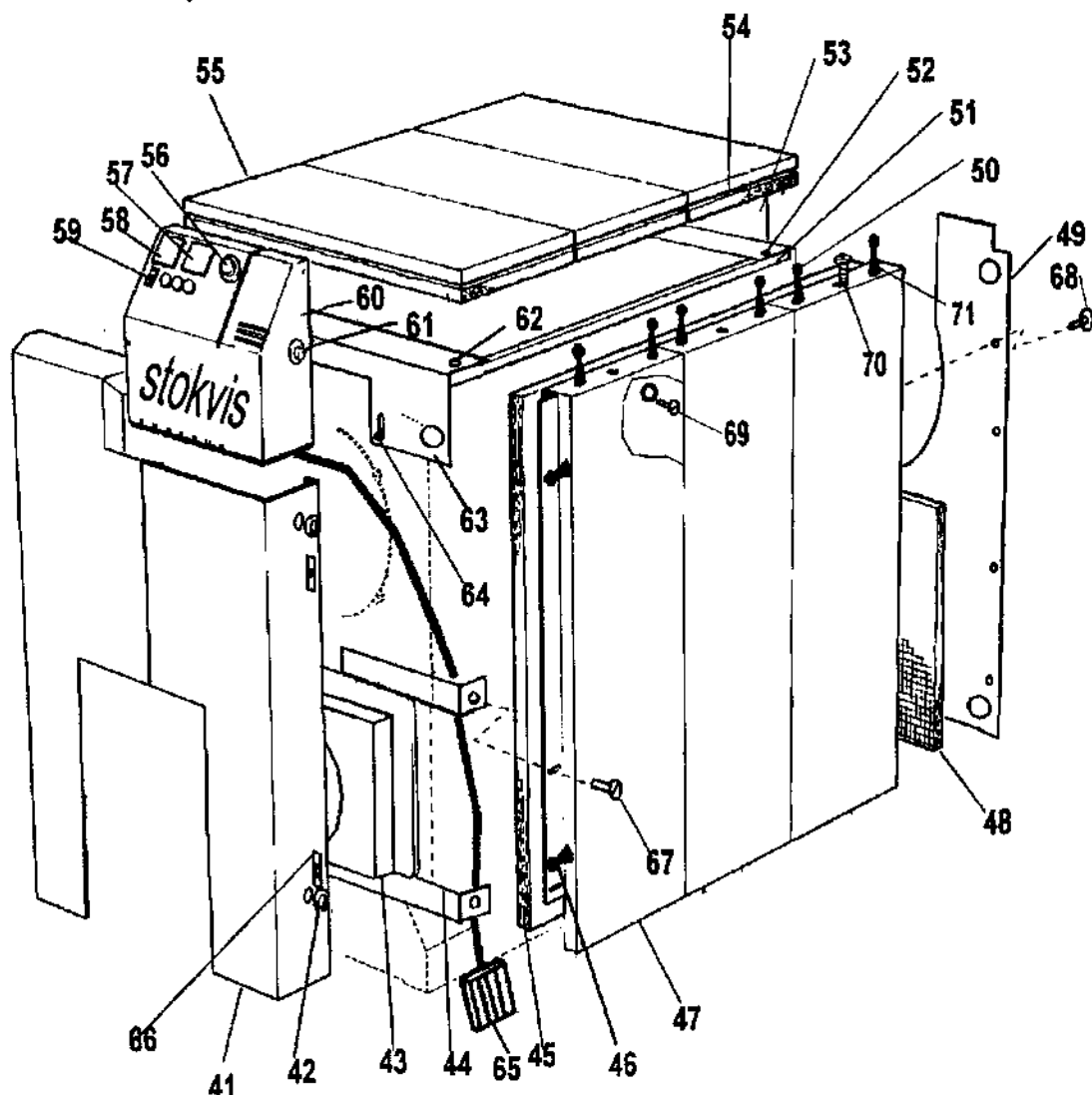

41	Front panel
42	Plastic bush
43	Boiler door assembly
44	Jacket locating bracket
45	Side panel insulation (prefitted)
46	Ball stud and M5x8 fixing screw
47	Side panel
48	Back insulation (loose piece)
49	Rear panel (left hand)
50	Rear jacket frame support braket
51	Side frame tube
52	M6 screw to fix side frame
53	Rear panel (left hand)
54	Top panel insulation (prefitted)
55	Top panel
56	Control thermostat
57	Temperature gauge
58	Pressure gauge
59	On / Off switch and lamps
60	Control panel
61	High limit thermostat reset button cover
62	M6 screw to fix side frame
63	Front jacket frame support bracket
64	M8 stud and nut for Item 63
65	Flying lead with plug for connection to burner
66	Spring latch for ball pin (prefitted)
67	M6x10 screw to fix side panel to Item 44
68	No 10 self tapping screw to fix back panels
69	M6x10 screw and nut to join side panels together
70	M6x35 screw and nut to fix side panels to frame
71	Ball stud and M5x8 screw

Fitting Flue Pipe

For models 45/60, 80, 106 and 133 the flue outlet is designed to accept a 150 mm (6") diameter nominal bore flue pipe.

For 160, 187 and 213 models the flue outlet is designed to accept 200 mm (8") nominal bore flue pipe.

For the 240, 266 and 292 models the flue outlet is designed to accept 250 mm (10") nominal bore flue pipe.

Smaller diameter flue pipe should not be used. On the larger models the actual flue may well be larger than 250 mm depending on actual flue runs and the position of bends etc.

Fitting Pressure Jet Burners

1. To allow for easy maintenance the boiler burner mounting door is hinged and the hinge is normally fitted on the right hand side (looking from the front) but should be changed on site before fitting the burner if necessary.
2. The burner, and gas train if applicable, should be fitted after the casing to ensure that the route for the fuel supply pipes does not interfere with the casing or boiler front.
3. Fit the burner to the burner mounting plate studs using the burner mounting gasket supplied with the burner.
4. The tip of the burner draught tube should project through the ceramic lining of the boiler door and into the combustion chamber proper by a sufficient distance.
5. On gas fired burners the gas train should be fitted in accordance with the burner manufacturers instructions using a suitable gas jointing compound if necessary and the soundness of the installation should be checked. A union and service gas cock should be fitted by the installer to allow removal of the burner for servicing.

Electrical Connection

1. The main electrical supply should be taken from a fused isolator having a minimum contact separation between the poles of 3 mm and taken through 20 mm electrical conduit to the live (1), neutral (2) and earth connection in the boiler control panel or burner terminal block as appropriate.

For single phase burners with low run current (less than 6 Amp) the power to the burner is supplied from the boiler control panel as shown in Fig 25b. All Nuway and Riello burners supplied by Stokvis come under this category.

For single phase burners supplied by others with higher run currents the main power supply should be made into the burner as shown in Fig 25a and wired accordingly.

All three phase burners should be wired in accordance with Fig 25a.

The interconnections between the boiler control panel and the burner are simply made by plugging together the 7 way on/off and 7 and 4 way plug and sockets on high/low burners.

The flexible conduit from the boiler control panel should have been routed behind the two right hand jacket locating brackets (See Fig 24 item 44) and out of the bottom of the boiler right hand front jacket panel.

It is important that this route is taken to avoid the flexible conduit touching any hot surfaces around the boiler door.

The connectors should be such that in the event of the cable being pulled out the current carrying cables become taught and pull out before the earth connection.

2. All wire should be suitable for a service temperature of 70°C and a load of 10 Amp and have a minimum cross sectional area of 1.0 mm²

All electrical installations should be in accordance with I.E.E Regulations (BS 7671).

THIS APPLIANCE MUST BE EARTHED

Electrical Safety Checks

Carry out the following electrical safety checks using a multimeter. (Do not use a PAT Tester on the pressure jet burners control pack as you could damage the electronics and they give false readings).

Earth Continuity Check

1. Appliance must be electrically disconnected from the mains.
2. Set the meter to Ohms x1 scale and zero if necessary.
3. Measure resistance between the earth connection point in the boiler control panel and the earth contact point in the supply junction box or the earth pin on the 3 way plug if this is being used.
4. If the resistance is greater than 0.1 Ohm check all earth wires and connections for continuity and that they are clean and tight and rectify as necessary.

Short Circuit Check

1. Appliance must be electrically disconnected from the mains and all appliance switches set to "ON" including the thermostats.
2. Set the meter to the Ohms scale x1 and measure the resistance between the live (1) and neutral (2) terminals in the boiler control panel. If the meter reads zero then there is a direct short circuit and a fault that should be rectified.
3. Set the meter to the Ohms x100 scale and measure the resistance between the live terminal (1) and the earth block in the boiler control panel. If the meter reads less than infinity then there is a fault that requires rectifying.

Polarity Check

Connect the appliance to the mains supply and set the meter to AC volts by 300V scale.

1. Measure the voltage between the live (1) and neutral (2) terminals and check that the voltage measures approximately 230V.
2. Measure the voltage between the live (1) and earth block and check that the voltage measures approximately 230V. When doing this if earth fault detection equipment is installed in the distribution board you may well trip it on some types of multimeter.
3. Measure the voltage between earth and neutral (2) and check that the voltage measures less than 15V.

Resistance to Earth Check

The appliance must be disconnected from the mains supply and all switches including the thermostats set to "ON".

1. Set the meter to the Ohms x100 scale.
2. Measure the resistance between the live (1) and the earth block. The reading should be infinity and if there is any other reading then there is a fault which should be isolated and rectified.

Fig. 25a Electrical Installation General: All 3 Phase Burners And 1 Phase With Run Current Above 6 Amp

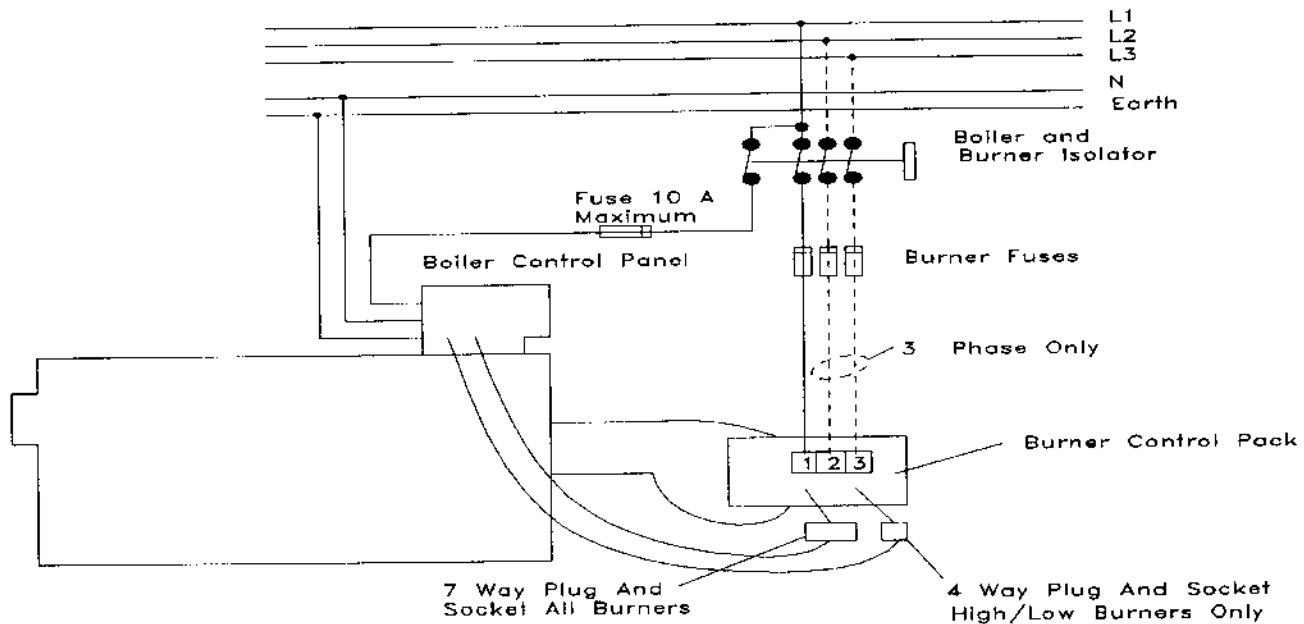
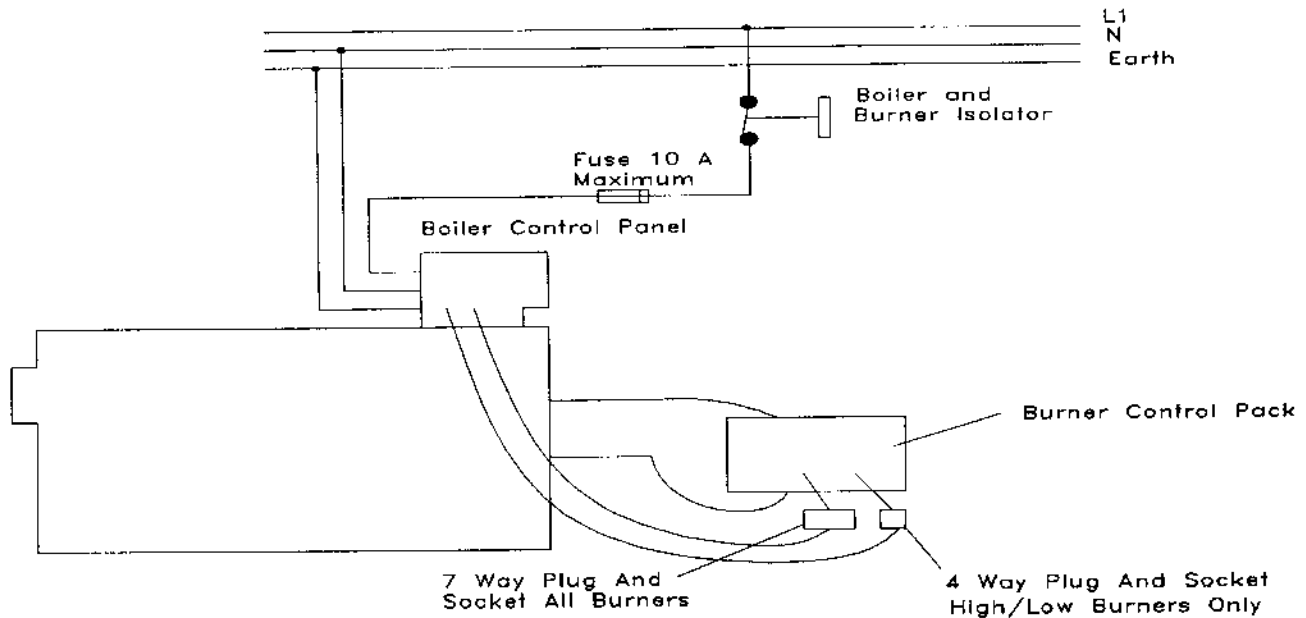
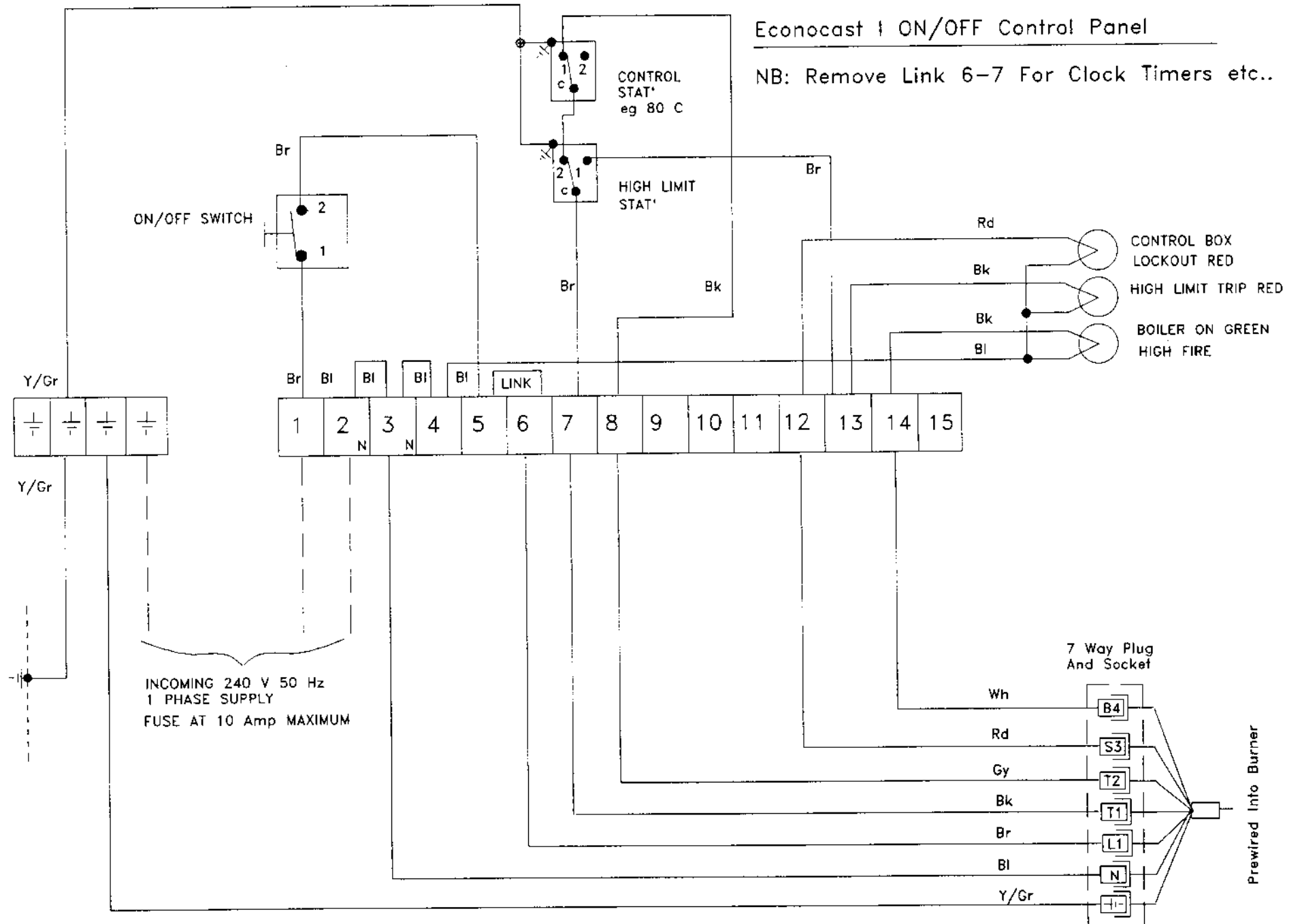

Fig. 25b Electrical Installation General: All 1 Phase Burners With Run Current Below 6 Amp



Econocast † ON/OFF Control Panel

NB: Remove Link 6-7 For Clock Timers etc..



Page 21

NB: Remove Link 5 - 6 For Time Clocks Etc.

Fig.27 Econocast High/Low Control Panel

NB: Remove link 6-7 for Clocks Timers etc..
If using a BMS use Link 6-7 to switch from low flame to off.
Use Link 10-11 to switch down from high to low fire on.
Nuway and riello Burners only.
For other burners contact Stokvis for advice.

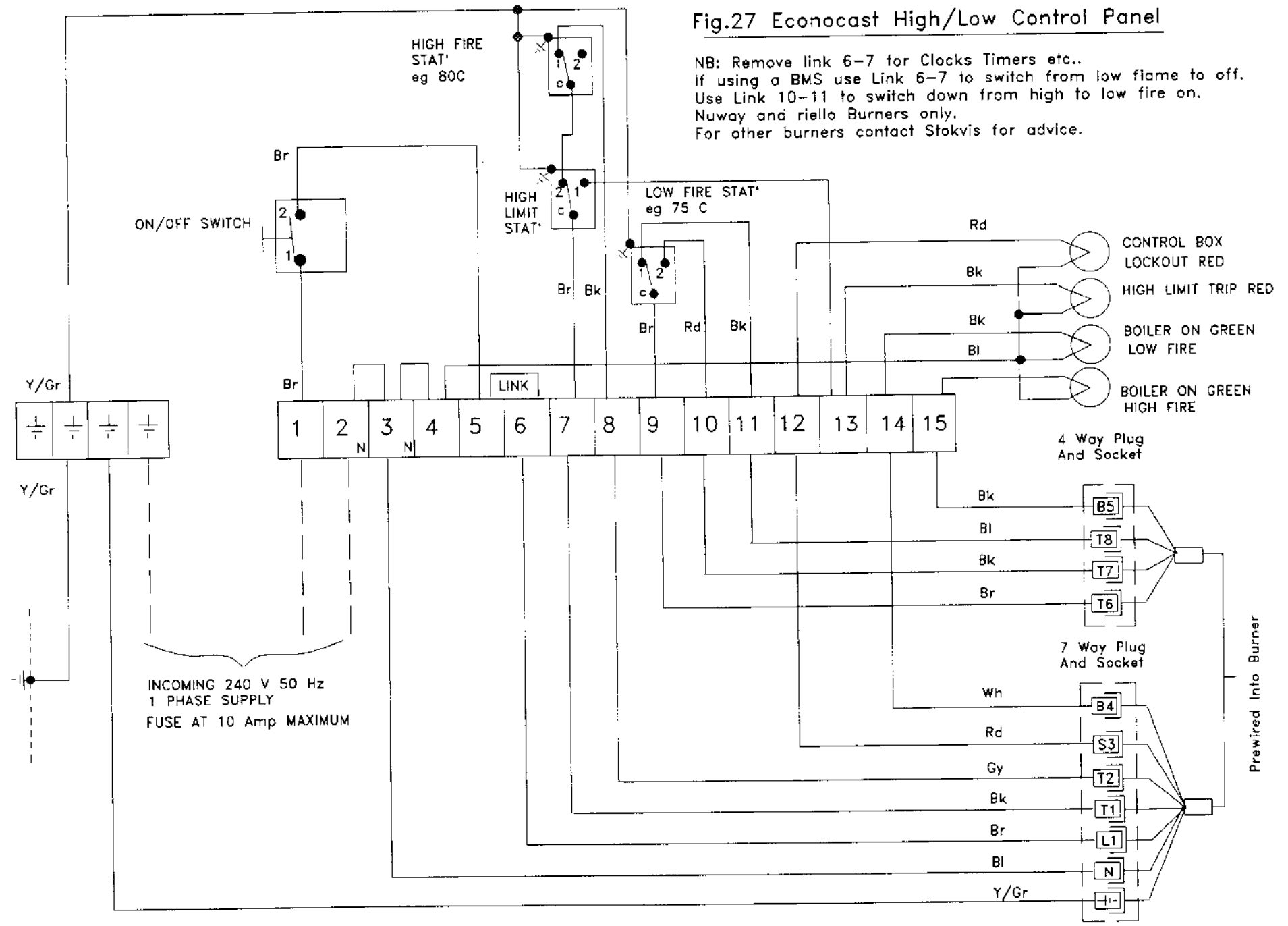

NB: Remove Link 5 - 6 For Time Clocks Etc.

Fig.28 Control Panel Optional Extras

- R1 Burner Control Box Lockout
- R2 High Limit Stat' Trip
- R3 Boiler On 1st Stage (Low or Main)
- R4 Boiler On 2nd Stage (High Fire)

- R5 Pump Overrun Relay And Timer P.C.B

Volt Free Contacts For Building Energy Management Systems, Alarms Etc.

When using the pump overrun timer remove the link 6-7 and connect the volt free contacts of the external time clock across these contacts.

Page 23

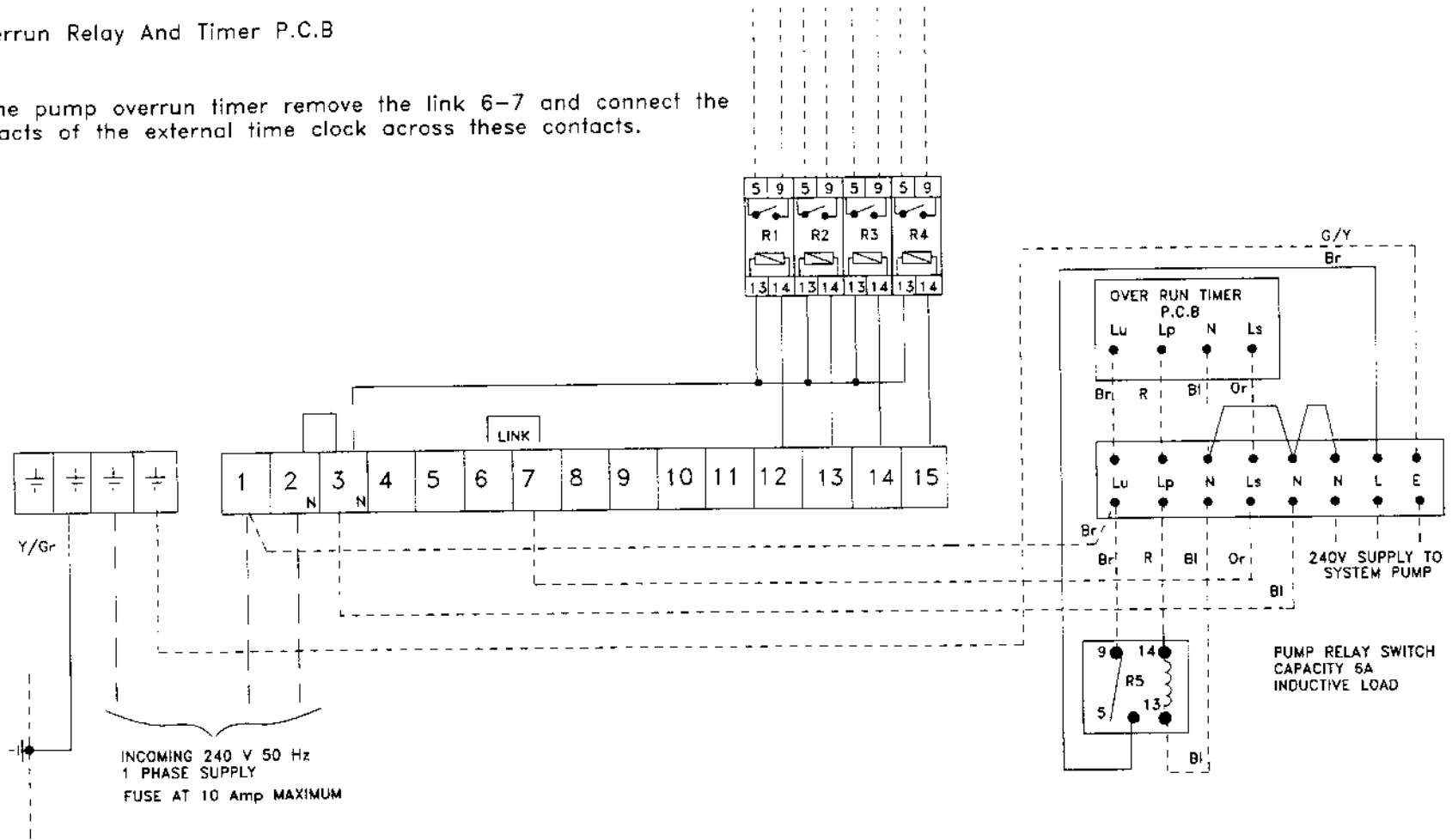

Commissioning Boilers

It is the Law that this appliance is installed and serviced only by a competent person e.g. a C.O.R.G.I registered installer or British Gas.

THIS APPLIANCE MUST BE EARTHED.

Electrical:

Before commencing ensure that the electrical supply is turned off and that all electrical connections are correctly made and that the appliance is earthed.

Gas Supply:

Before commencing check that the gas supply is purged of air and that the gas connections are sound and that the boiler gas cock is off. Ensure that the gas supply is turned on at the meter.

Oil Supply:

Before commissioning check that oil is available and that the oil supply has been made through an isolating valve and a suitable filter.

Water:

Before commencing ensure that primary system has been filled and that pumps are operating and that the system pressure is at least 0.2 bar and that any isolating or any other valves on the system are open.

1. Check that the on/off switch on the boiler control panel is off and that the gas or oil service cocks are turned on.
2. Check that the correct oil nozzle is fitted and fit an oil pressure gauge to the oil pump or a manometer to the burner head for gas burners.
3. Commission the burner as described in the Burner Manufacturers Manual. The burner settings given in Tables 7 to 10 are for initial guidance only and a full commissioning must be completed.
4. Switch OFF the electricity and check that the burner closes down.
5. Test for gas soundness around joints as described in BS 6644 and British Gas Publication IM 5. These documents give the correct procedure which is to pressurise the gas pipework system and look for a loss of pressure with a suitable manometer. Soap solution or ultrasonic leak detectors are not suitable to prove that pipework is sound, only to find the point of the leak when a pressure test shows one.
6. Set the control thermostat on on/off boilers to typically 80°C and the high limit thermostat to typically 95°C. For high/low boilers set the left hand HIGH FIRE thermostat to typically 80°C and the right hand LOW FIRE thermostat to typically 75°C and this will bring the burner down from high to low fire when the water temperature reaches 75°C and switch the burner off when the water temperature reaches 80°C. The high limit thermostat should again be typically set to 95°C.

Maintenance of Boiler

Safety:

Before servicing the boiler switch off electrical supply and close oil and gas valves.

Maintenance:

To maintain optimum efficiency the boiler flueways must be cleaned at regular intervals. The period between cleaning will depend on the hours of use, type of fuel and site conditions, but should not be less than once yearly, at the end of the heating season.

The boiler flueways, combustion chamber and chimney system should be kept free from soot and scale. When the boiler is shut down for long periods the front cleaning plate should be removed to allow air to circulate through the boiler.

To avoid the risk of fireside corrosion the minimum return water temperature should be 40°C .

WARNING: Before commencing any form of maintenance and cleaning make certain that the electricity supply to the burner is switched off.

To Clean Boiler

1. Switch off electricity supply to burner.
2. Lift off top the panels of jacket, starting with the rearmost panel.
3. Loosen the wing nuts holding the top flue way clean out covers and remove these. The rear covers also have a baffle on larger boilers and these types are always fitted to the back of larger boilers. Care in removing the baffles will avoid damage to the gaskets thus preventing unnecessary replacement.
4. Remove the one piece front jacket panel by pulling the left hand side forwards, lifting up slightly then pulling the right hand side forward.
5. Remove the circular front cleaning plate.
6. Remove the 4 wing nuts holding the boilers burner door shut and hinge open after first releasing the gas supply pipe if applicable.
7. With a 1" flexible flue brush, clean all vertical flueways through the top openings.
8. With a 3" round wire brush, clean horizontally from the front, removing all deposits.
9. Thoroughly clean the boiler deposits from the combustion chamber. (This can most conveniently be done with a vacuum cleaner).
10. Check sealing gaskets, and renew where necessary.
11. Refit all platework and the close the boilers burner door making sure that a gas tight seal has been remade.
12. Refit all flueway cover/baffles, ensuring that the covers bed down on the gaskets and tighten the wing nuts on the retaining hooks
13. Refit jacket panels.

Component Replacement

CAUTION:

Never open the boiler door unless the burner electrical and fuel systems have been isolated.

Burner and Gas Line

Components should be replaced with reference to the Burner Manufacturers Installation Manual

Control Panel Component Replacement

Remove the single piece jacket front panel and then the two screws in the sides of the control panel and hinge it up and back.

1. Control or High/Low Thermostat:

Remove the electrical connections noting their positions. Remove the thermostat bulb from the thermostat pocket (after removing the top front jacket panel) and thread it back out through the control panel. Remove the knob and the two screws holding the thermostat body and release it from the control panel facia. Replace as the reverse of the above taking care to replace the spring clip that retains the bulb in the thermostat pocket and to remake the earth connection.

Replace as the reverse of the above ensuring that the new thermostat is set to the same temperature as the faulty one. Ensure that the earth connection is remade and that the spring clip retains the bulb in the thermostat pocket.

2. High Limit Thermostat:

Remove the electrical connections noting their positions. Remove the thermostat bulb from the thermostat pocket and thread it back through the control panel. Remove the knob and the fixing nut.

3. Temperature and Pressure Gauge:

Remove the bulb from the thermostat pocket or the fitting from the self isolating fitting on the boiler and thread it back out through the control panel. Remove the gill clip from the gauge and push it out through the panel. Replace as the reverse of the above.

4. Main On/Off Switch and Lamp:

Remove the electrical connections, noting their positions, and the back nut on the lamp and push it out through the panel. Replace as the reverse of the above.

5. Pump Overrun Kit

Remove the electrical connections noting where they go and release the circuit board from the 4 push on plastic pillars.

Spare Parts

Boiler Functional Spares

PART NO:	DESCRIPTION
1542	Target wall ceramic block . 4 to 7 section oil only.
1526	Top flue clean out cover gasket.
0205	Sight glass 2"
1535	Sight glass gasket
BSN	Steel nipple 2 1/2"
0075	Nipple jointing compound. Stag "A" 400g.
BSCEF	Front section
BSCÉB	Back section
BSCÉM	Middle section
0749	Section jointing mastic 6mm x5 appertures
0170	Control and high/low thermostat. Imit TR2 0-90 C .
0935	Control and high/low thermostat. Imit TR2 0-120 C.
0172	High limit thermostat. Imit LS1/3 90-110 C.
0936	High limit thermostat. Imit LS1/3 100-130 C.
0169	Boiler thermometer Imit/Gruter 0-120 C.
0168	Boiler thermometer Summit 0-120 C. (To be used with Part No. 0165 as a pair).
0166	Altitude gauge Imit/Gruter. Standard range 0-4 bar.
0165	Altitude gauge Summit 0-1 bar for low heads. (To be used with 0168 as a pair).
0835	On/off switch Arco Electric.
LAMPG	Green lamp. Arco Electric.
LAMPR	Red lamp. Arco Electric.

Burner Functional Spares: Consult the Burner Manufacturers Manual.

Econocast I Users Guide

To Shut Down the Boiler

1. Switch off the electricity supply and the on/off switch on the boiler control panel.
2. If switching off for an extended period e.g. holidays turn off the gas or oil supplies at the service and isolating gas or oil cock on the burner.

Care of the Boiler

1. Do not shut down the boiler if freezing conditions are expected unless a frost protection thermostat has been incorporated in the boiler house control system.
2. Do not obstruct the airvents, grilles or other air openings in the boiler room and ensure a clear path of combustion and ventilation air to the boiler.
3. Do not store objects on or near the boiler or the flue.
4. Do not use propellant sprays or chemicals particularly chlorine based chemicals in the vicinity of the boiler.
5. The boiler should be serviced once a year by a C.O.R.G.I registered engineer.
6. If at any time a gas leak is suspected DO NOT use a naked flame to locate the leak or turn on or off any electrical switches.
7. Turn off the gas supply to the boiler at the gas meter and contact the Local Gas Region Office immediately.
8. The number is in the phone book under GAS, write the number here....

GAS TELEPHONE No:

To Light the Boiler

1. Turn OFF the on/off switch on the boiler control panel.
2. Check that the gas cock or the oil isolating valve is on.
3. Switch on the electricity supply, time clocks etc. and the on/off switch on the boiler control panel. The green lamp in the on/off switch should light .
4. Turn the Control Thermostat on the control panel to
LOW FIRE thermostat to 75°C. The LOW FIRE thermostat will switch the boiler down from high into low fire at 75°C and the HIGH FIRE thermostat will switch the boiler off at 80°C.
5. The burner should now light.

Boiler Fails to Light

If the High Limit Thermostat has tripped then the burner will not attempt to start. The red High Limit Thermostat Trip Lamp on the boiler control panel will be ON and the thermostat can be reset by removing the black plastic dust cap on the side of the control panel and pressing the small button beneath it.

2. If the burner itself has detected an internal fault it will Lock Out and will not attempt to light. The red Burner Lockout Lamp on the boiler control panel will be ON and this Lock Out can be reset by pressing the reset button on the burner control pack which may be glowing red.

3. If the burner starts and runs and then locks out check that there is fuel reaching the burner.

If you still cannot light the boiler contact your installer.

R. S. STOKVIS & SONS LTD POOL ROAD WEST MOLESLEY SURREY KT8 2HN
TELEPHONE 0181 941 1212 FAX 0181 941 4136

HEALTH AND SAFETY INFORMATION

CONTROL OF SUBSTANCES HAZARDOUS TO HEALTH

For the type of material and where used in Stokvis products refer to the chart opposite.

Specific data sheets are available on request from Stokvis for those materials but the following Material Handling and First Aid procedures should in all cases be observed.

PAINTS SEALANTS AND HEATING FUEL OIL.

These materials contain organic solvents and should be used in a well ventilated area away from naked flames.

Do not allow to come into contact with the skin, eyes, inhale or swallow.

Use barrier cream or gloves to protect the skin and goggles to protect the eyes from accidental contact.

Small quantities can be removed from clothes or skin with a proprietary paint remover or hand cleaning product.

If inhaled remove sufferer into fresh air, if swallowed clean mouth with and drink fresh water but do not induce vomiting.

If in the eye irrigate the eye with clean water and seek medical attention.

SHARP EDGES

Care should be taken when handling sheet metal panels that do not have safety or folded edges.

LIFTING OF CAST IRON SECTIONS AND BUILDING OF BOILERS

Care should be taken when lifting cast iron sections as they can weigh up to a few hundred kilograms and

Stokvis can confirm the weight of each individual section if required. When building the boiler the section should always be built on a level base capable of supporting the full weight of the boiler and the sections should always be supported on blocks of wood or props when positioning before final bolting up. An unsupported section should never be left unattended.

NATURAL GAS

Only a competent qualified person e.g. C.O.R.G.I. registered, A.C.O.P.S. certified can install, commission or service this gas appliance.

THERMAL INSULATION

Avoid contact with skin, eyes or inhaling dust.

If cutting insulation then do so in a well ventilated area using gloves to protect the hands, goggles to protect the eyes and a disposable dust mask.

If a skin reaction or eye irritation is experienced then discontinue working with the material and seek medical advice.

CONTROL OF SUBSTANCES HAZARDOUS TO HEALTH

PAINTS	
General purpose black undercoat Johnsons Paints.	n/a
High temperature black. Guard Coatings HT Black Primer	1 Flue hood 2 Burner plate 3 Burner Assembly
Green and Grey jackets Trimoco Paints.	1 All jacket parts. 2 Control panel

INSULATION AND SEALS	
Rockwool foil faced slabs	1 Boiler body 2 Burner plate
Fibre glass rope and tape	1 Burner plate 2 Flue hood
Ceramic Fibre Board	1 Burner plate 2 Jacket side panel ext
C.F.C Free Polyurethane spray on foam.	n/a
Refractory Brick	n/a
Asbestos products	Not Used

SEALENTS	
Nipple jointing compound. Hawk Red	n/a
Extruded Sealing Mastic. Seal Strip Ltd.	1 Section joints
Rust inhibitor Rocol Rustshield.	1 Boiler nipples 2 Machined ports
Fire Cement In cartridges Parkit of Fortafix.	n/a
Water Jointing Compound P.T.F.E Tape / Boss White / Hemp	Cast iron plugs Gauges/pockets Drain cocks
Gas Jointing Compound Plasticol PX10	Burner and gas train.