



**ECONOPRESS
EPS & EPT
ELECTRONIC PRESSURISATION SET**

**INSTALLATION, OPERATION &
MAINTENANCE DOCUMENTATION**

STOKVIS ENERGY SYSTEMS
96R WALTON ROAD
EAST MOLESEY
SURREY
KT8 0DL
TEL: 020 8783 3050 / 08707 707 747
FAX: 020 8783 3051 / 08707 707 767
E-MAIL: info@stokvisboilers.com
WEBSITE: www.stokvisboilers.com

VERSION 3.0 (OCT2010)

General Installation

Introductory notes

These pressurisation units operate in a single pump, (duty) or two pump, (duty standby) format. These units together with the individually sized expansion vessel/s are employed to maintain the ambient cold fill pressure and accommodate the volume changes that occur in sealed heating and chilled water systems.

Each unit is individually supplied, any system alterations may require a design or setting change.

The full system should be pressure tested and flushed BEFORE connection to the unit or vessel to prevent any damage from metal particles, dirt etc., and to eliminate all leaks.

Under no circumstances must any treatment be introduced into the system via any part of the unit.

The unit can be used to fill the system using its' "FILL MODE" feature, although this may be slower than other usual means of manual filling. Please refer to "FILL MODE" later in the instructions.

Site Location

The unit location should be undercover, dry and freely ventilated. Protection from frost must be ensured.

Reasonable access to all parts of the set and adequate service work space must be provided. A minimum clearance of 500mm above the unit is required if placed back to a wall.

The floor base should be firm and level in all directions.

Base holes are provided if uni-strut structures or wall brackets are used to mount the brackets off the floor.

If unit is to be wall-mounted, refer to the diagrams on the following page for wall fixing dimensions.

Mechanical

Connect the cold water mains supply via a stop tap and union connector to the break tank ball valve ($\frac{1}{2}$ " BSPM).

Arrange the overflow to discharge away to a suitably noticeable position (22mm compression).

Using the $\frac{1}{2}$ " BSPF outlet, link into the system on the return side of the boiler, and the suction side of the pump incorporating a minimum two metre anti-gravity loop fitted with automatic air vent. A branch should be taken off of the same part of the loop and piped to the expansion vessel or vessels ensuring that each is supplied with a lock shield valve, drain cock and a union connection for any future service work.

Please locate at least one vessel close to the pressurisation unit (i.e. within 2 metres) to assist the controls of the unit.

All pipework links should be suitably sized with a minimum of 22 mm up to 6 metres, and 28 mm for up to 12 metre runs (larger sizes are required above 300 litre vessels or multiples).

Please refer to schematic installation diagram.

**ALL MUST BE LEFT UNLAGGED IF PRACTICAL TO PRESERVE VESSEL MEMBRANES FROM
PREMATURE TEMPERATURE INDUCED AGEING**

WALL MOUNTED OPTION DIAGRAM

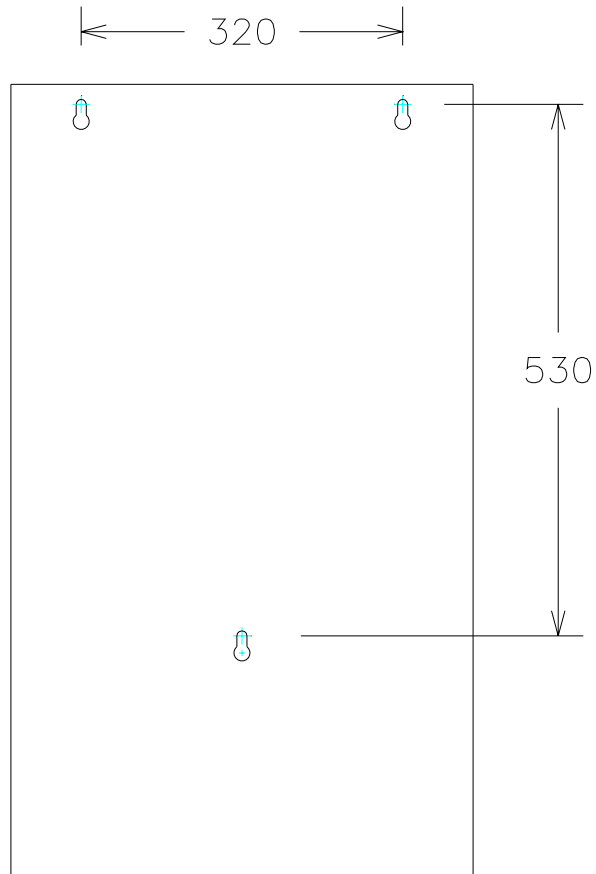

HANGING HOLES

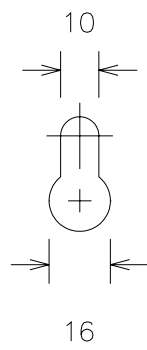

Schematic Installation Diagram Single System Pressurisation Unit & Vessel(s)

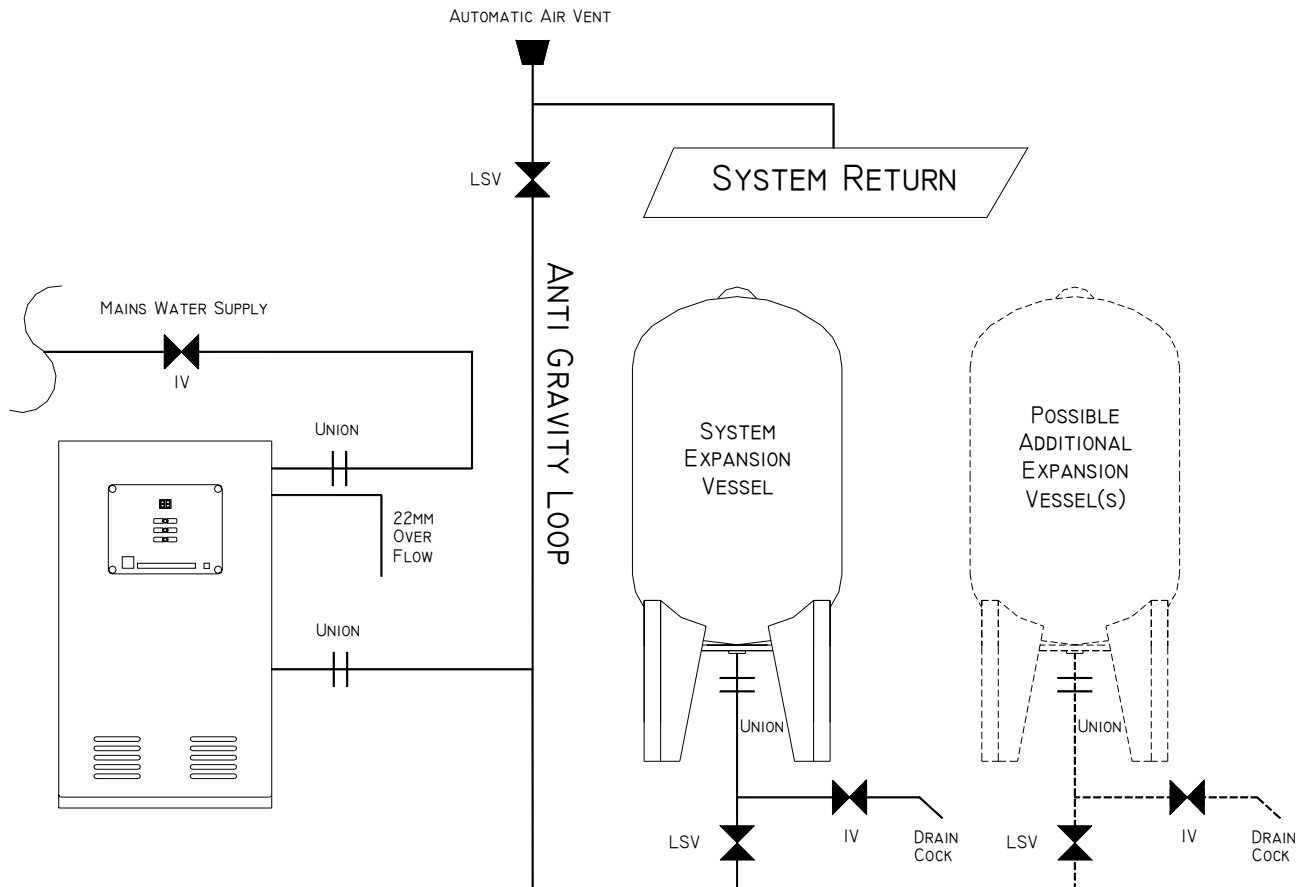

Notes:

- If practical do not lag pipework from unit to system or vessel.
- Ensure all isolation and drain valves are included in the installation to assist maintenance.
- Follow wiring diagrams for electrical connections.

Electrical

Connections to unit

The supply should be brought to the set with suitable trunking or armoured cable, with trunking we recommend that the final metre is converted to flexible conduit to avoid any undue stress or fatigue to the unit.

All supply cables should be sized according to accommodate any voltage drop due to long cable runs.

Voltage at the unit should be single phase, 230 volt, 50 Hz. A neutral supply is required.

The pump rating 0.37kW and 2.5amps FLC. On twin pumps allow for both to run together.
(high pressure versions (EPS-HP / EPT-HP) 0.37 kW and 3.41 amps FLC)

The volt free contacts are rated at 5 Amps, 230 volt.

It is strongly recommended that a local isolator is installed within one metre of the unit incorporating sufficient contacts to isolate both the mains supply and all control cables being used.

The supply fuses should be rated to run one pump or a pair in a duty standby unit.

All equipment should be earthed.

IT IS STRONGLY RECOMMENDED THAT ANY SUPPLY FEEDING THE VOLT FREE CONTACTS FOR ALARMS OR CUT OUTS, IS DISCONNECTED BY THE INDEPENDENT ISOLATOR.

All connections should be performed by a competent electrician conversant with the wiring diagram provided and all current regulations. Care should be taken when connecting to terminals on the circuit board and excess pressure should be avoided on terminals.

WIRING DIAGRAM

Models: EPS, EPT, EPS-HP, EPT-HP

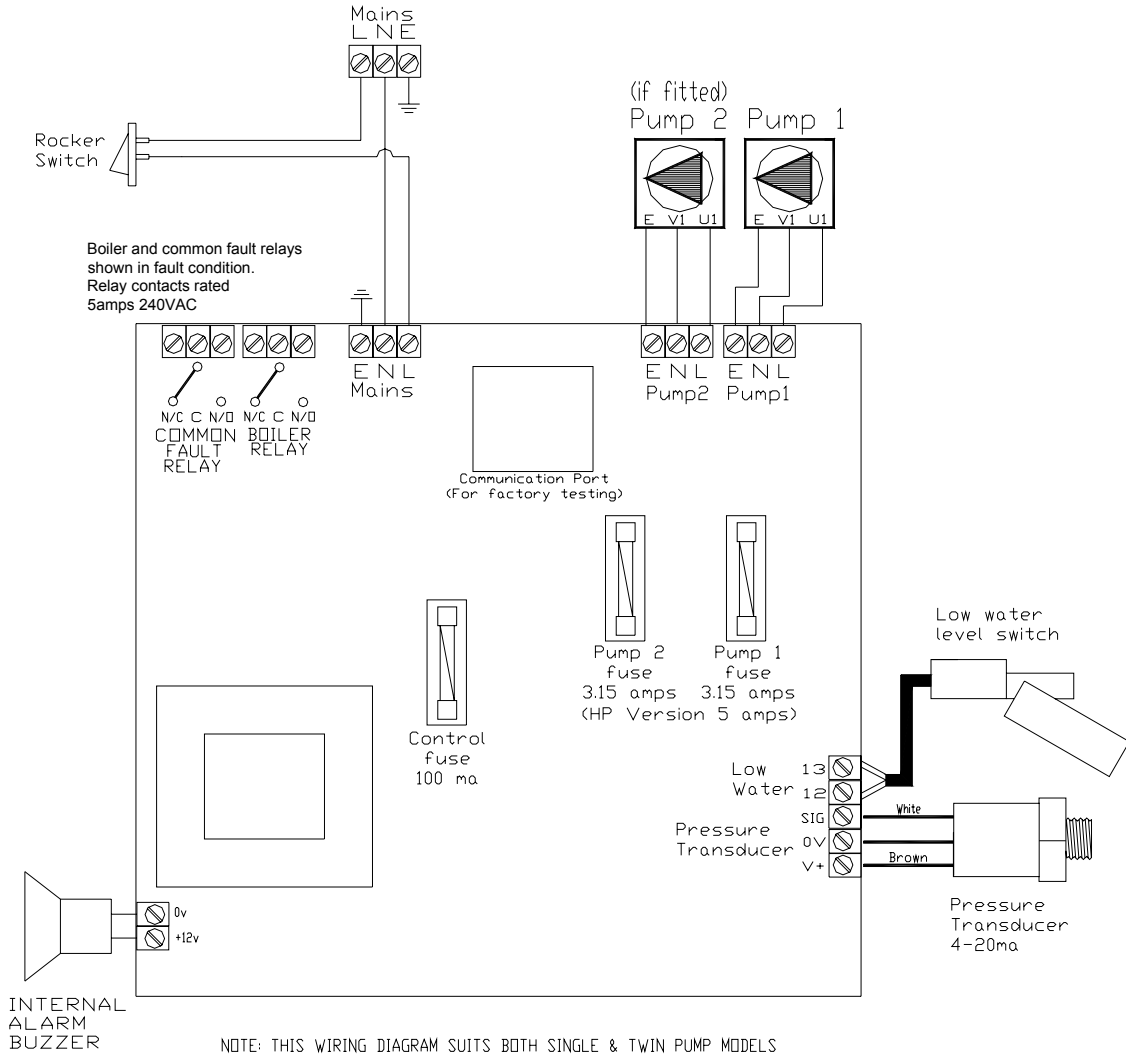

VOLTS FREE CONTACTS

The wiring diagram shows the boiler relay and the common fault relay in the FAULT CONDITION OR WHEN THE UNIT IS POWERED DOWN.

If the unit is turned on and the system is healthy both of these relays will change state when energized.

The following details denote when each relay de-energizes.

	FAULT RELAY DE-ENERGIZING	BOILER RELAY DE-ENERGIZING
LOW WATER	YES	NO
LOW PRESSURE	YES	YES
HIGH PRESSURE	YES	YES
TRANSDUCER FAILURE	YES	YES
PUMP No1 FAIL	YES	NO
PUMP No2 FAIL	YES	NO

WIRING EXAMPLES

EXAMPLE OF COMMON FAULT CIRCUIT

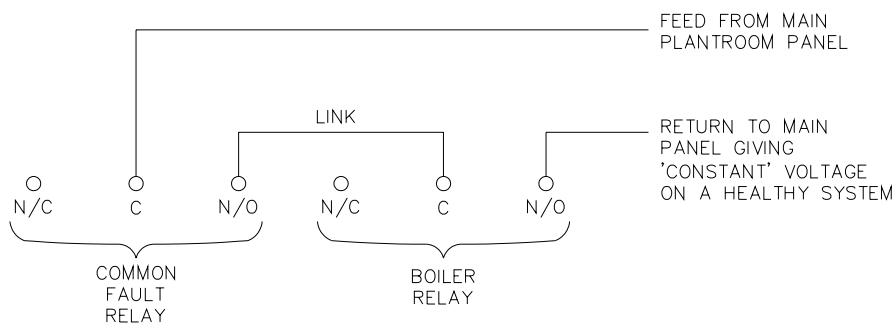

EXAMPLE OF SEPARATE FAULT/SIGNAL CIRCUIT

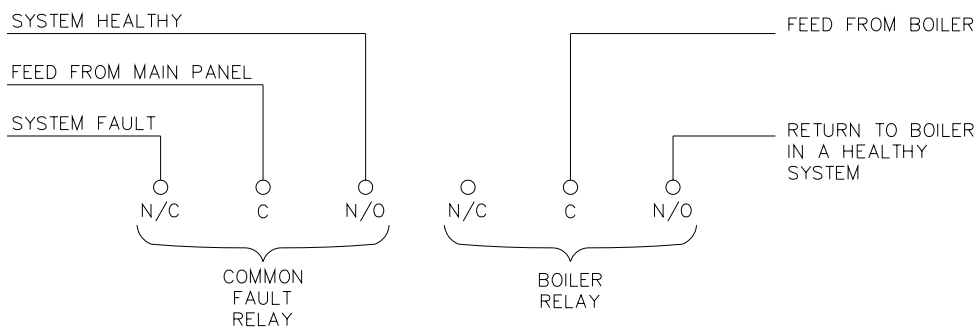

EXAMPLE OF COMMON FAULT BREAKING CIRCUIT WITH SEPARATE FAULT SIGNAL

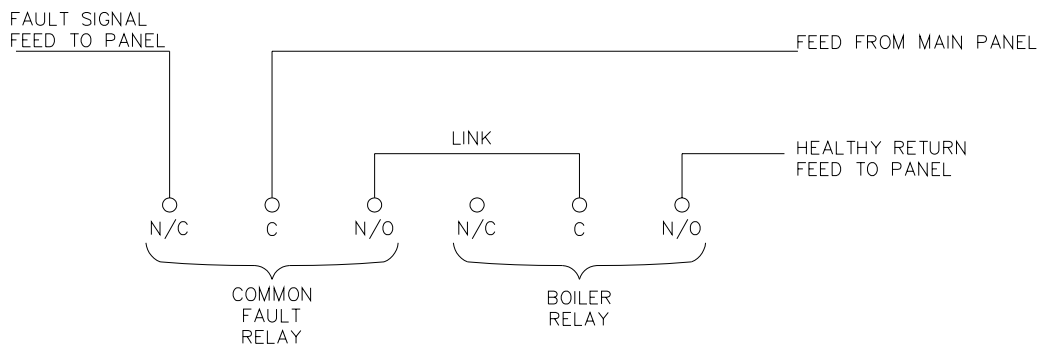

Commissioning

These notes are guide lines to engineers who are conversant with sealed systems and pressurisation units.

A commissioning service can be provided by us for customers where required (see front page for contact details).

If the unit has been factory set, no adjustments after pump priming should be necessary.

NOTE: All pump(s) must be vented prior to any running using the vent plug (13mm spanner) situated adjacent to the discharge top outlet. If water is not present, check the filters are clean in the tank and try again, replace the vent plug and tighten after venting. If necessary, seal with PTFE tape on the plug threads.

Settings

STANDARD UNIT COLD FILL UP TO 3 BAR

HIGH PRESSURE (HP) UNITS COLD FILL UP TO 6 BAR

We base our settings on the following:-

1) The cold fill pressure:

The unit cold fill pressure is the point at which the pump switches off.

The cold fill setting is based on the following:-

The static height of the system from the unit to the highest pipework in metres + 4 metres extra.

e.g. 9 metres static + 4 metres = 1.3bar (note: approximate conversion:- 10 metres = 1 bar)

The minimum cold fill setting should be 1.0 bar, this will allow up to 6 metres of pipework height.

2) The low pressure:

Setting is to be set 0.4 below cold fill pressure

e.g. cold fill 1.5 bar, LP = 1.1 bar.

3) The high pressure:

Setting should be set at 0.3 bar below the system safety valve setting

e.g. safety valve set at 4.0 bar, HP = 3.7 bar.

Note: there is a minimum differential above the cold fill setting of 0.4bar.

To program the unit if it has not been factory set, proceed using the flow chart on the following pages.

Vessel Air Pressure

If not factory set, the vessel air pressure must be set to 0.1 bar below the cold fill pressure

(e.g. cold fill of 1.0 bar, vessel pressure 0.9 bar).

Note: The air charge should never exceed 5.0 bar as a maximum.

All vessels have to be empty of all water prior to setting the air pressure. Isolate and drain down first.

The air valve for the vessel is located below the black cap, which should be replaced after checking/adjusting the air pressure.

Use an oil free compressor or foot pump (smaller vessels) to add air as required. A tyre gauge should be used to finally check the required pressure.

IMPORTANT: Please remember to open the vessel isolation valves after checking the air charge.

Fill Mode

The fill mode is designed to help clients fill their systems if they either do not have, or wish to use, other methods of system filling.

During the fill mode, the unit operates in a different manner. Firstly the boiler relay will be de-energised at all times and the only control feature used is the low water level lock out circuit to protect the pump(s). If the pumps stop due to lack of water, the display will flash "LL" while the water tank re-fills, after the float switch rises a timer will delay the pump for 25-30 seconds before allowing it to re-start.

To start fill mode (after inputting system settings) press and hold the "+" and "-" buttons together, the display will flash between the systems pressure and the letter SF. This will continue until the system filling is complete, at which point the enter button should be pressed and held for 5-6 seconds to change from fill mode to standard operating mode.

**Note: We are able to provide a full commissioning service if you require.
Please contact the sales office or service department.**

SET UP FLOW CHART FOR PRESSURISATION UNITS (Models EPS, EPT, EPS-HP, EPT-HP)

(OPERATIONS & MAINTENANCE MANUAL VERSION)

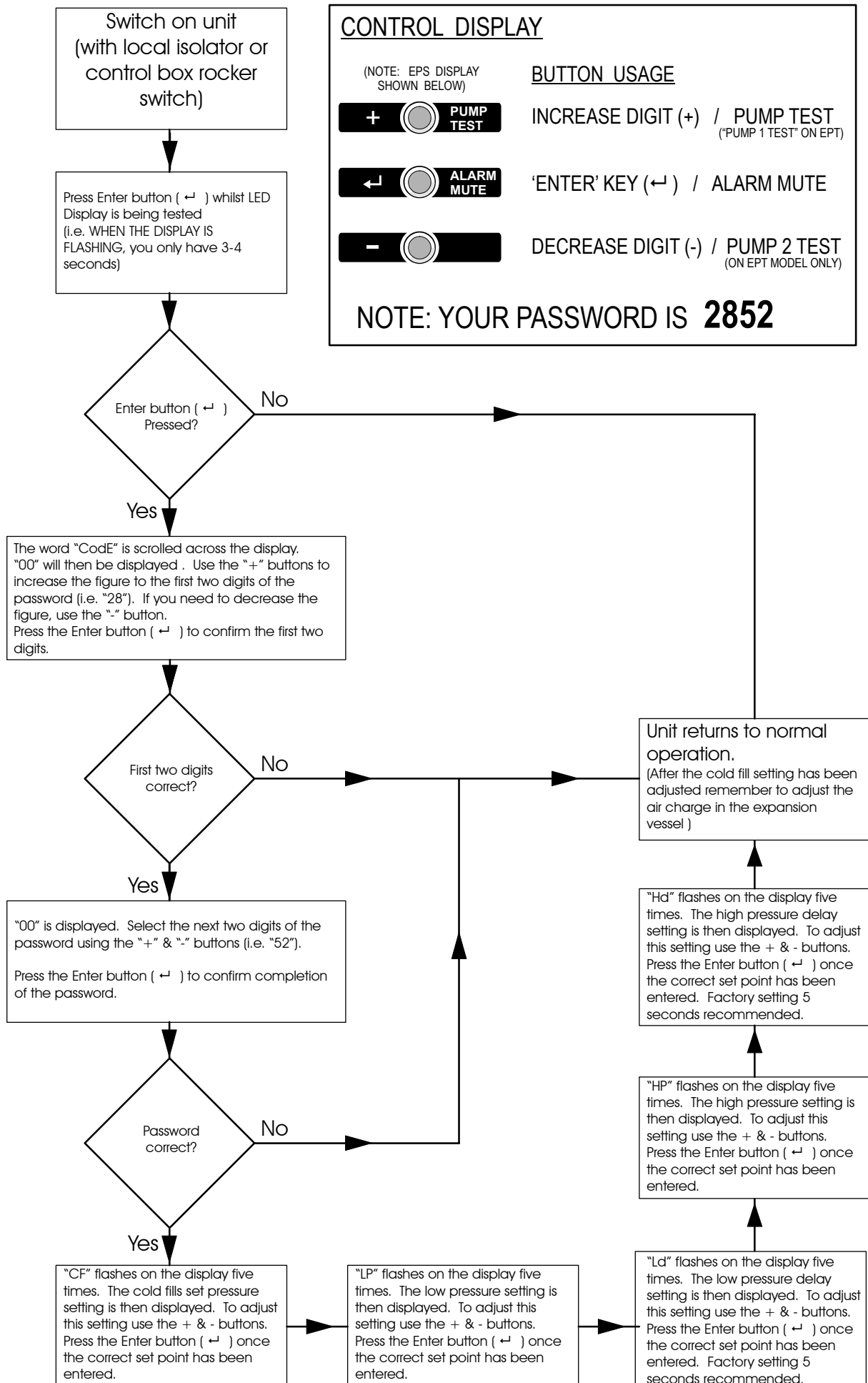

Maintenance

Six monthly checks should be made on the expansion vessels. The air charge should be checked after the vessel is isolated and drained using the local valve and drain cock.

Note: You cannot check these vessels unless drained. Use an oil free compressor or foot pump to inflate and check with a good quality gauge for the air pressure.

Yearly checks should proceed as above followed by running the pumps to check operation, mechanical seals and electronic controls. This can be performed by isolating the system with the unit isolation valve, connecting a hose from the unit drain cock and placing the other hose end back into the units water tank. As you open the drain cock the pressure should fall and start a pump, this can be run for 5-10 minutes after which you should close the drain cock allowing the unit to build pressure and stop and then repeat the operation for the second pump if fitted. **After maintenance, ensure you open the unit back up to the system.**

Other checks consist of testing for noisy bearings, faulty ball valve or float, float switch operation, electrical connections and general operation and condition of the unit.

All maintenance should be carried out by a competent person conversant with sealed system pressurisation units.

**A full maintenance programme is available on request –
Please contact our Service Department (details on front page)**

FAULT CODES (EPS, EPT, EPS-HP, EPT-HP)

TF	=	TRANSDUCER FAIL
LL	=	LOW LEVEL WATER IN TANK
F1	=	FS1 ON PCB FAIL OR PUMP 1 FAIL
F2	=	FS2 ON PCB FAIL OR PUMP 2 FAIL
SF	=	SYSTEM FILL ONLY COMES UP WHEN “+” AND “-” BUTTONS ARE PRESSED TOGETHER. PRESS ENTER BUTTON TO RESET.
LP	=	LOW PRESSURE
HP	=	HIGH PRESSURE
SERVICE (scrolled)	=	Service reminder. The display will alternate with the system pressure and scroll the word SERVICE when this is due.
NO DISPLAY	=	MAIN POWER FAIL 100mA FUSE 3 ON PCB OR MAIN FUSE/CIRCUIT BREAKER